

SNU 10 Plus / SNU 10 Plus AU / SNU 10 Plus GB

Kleinspeicher (drucklos)	2
Small water heater (non-pressurised)	11
Kleine boiler (drukloos)	20
Malé zásobníky (beztlakové)	28

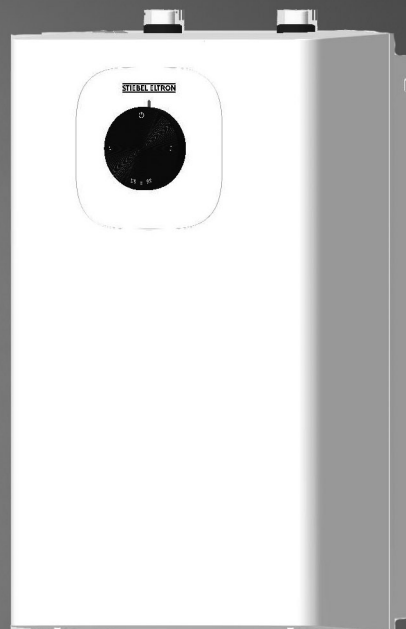

1	Special information	12
2	General information	12
2.1	Symbols in this document	12
2.2	Test mark	12
2.3	Units of measurement	12
3	Safety	12
3.1	Structure of the warning notices	12
3.2	Intended use	13
3.3	Safety instructions	13
4	Appliance description	13
4.1	Function	13
4.2	Standard delivery	13
4.3	Required accessories	13
5	Installation (qualified contractors)	13
5.1	Installation site	13
5.2	Appliance installation	14
5.3	Water connection	14
6	Commissioning (qualified contractors)	14
6.1	Filling the appliance with water	14
6.2	Electrical connection	14
6.3	Setting a permanent temperature limit	15
7	Operation	15
8	Cleaning	15
9	Maintenance (qualified contractors)	15
9.1	Draining the appliance	15
9.2	Opening the appliance	16
9.3	Descaling the appliance	16
9.4	Checking the earth conductor (DGUV V3)	16
9.5	Replacing the connecting cable	16
9.6	Positioning the temperature sensor in its protective pipe	16
10	Troubleshooting (users)	16
11	Troubleshooting (qualified contractors)	16
12	Shutting down the system	16
13	Specification	17
13.1	Dimensions and connections of the SNU 10 Plus (all versions)	17
13.2	Wiring diagram	17
13.3	Heat-up diagram	17
13.4	Energy consumption data	17
13.5	Data table	17
14	Guarantee	18
15	Environment and recycling	18

1 Special information

- The appliance may be used by children over 3 years of age and persons with reduced physical, sensory or mental capabilities or a lack of experience and expertise, provided that they are supervised or they have been instructed on how to use the appliance safely and have understood the potential risks. Children aged 3 to 8 years may only operate the tap connected to the appliance. Children must never play with the appliance. Cleaning and user maintenance must not be carried out by children without supervision.
- When permanently connected to the power supply using a dedicated junction box, the appliance must be able to be isolated from the mains power supply by an isolator that disconnects all poles with at least 3 mm contact separation.
- The power cable may only be replaced by qualified contractors authorised by the manufacturer. Use the original spare part. Otherwise, you risk damaging the appliance.
- Never connect the appliance via an external switching facility such as a time switch.
- Secure the appliance as described in chapter "Installation / Appliance installation".
- The appliance must only be installed with an open (non-pressurised) tap.
- Never subject the appliance to water pressure.
- The tap outlet has a vent function. Scale build-up can block the outlet and subject the appliance to pressure.
- Never block the tap outlet.
- Only use special aerators for non-pressurised water heaters.
- Never extend the tap outlet with a hose.

2 General information



Read these instructions carefully before using the appliance and retain them for future reference. Pass on these instructions along with the appliance as necessary.



Information for Australia and New Zealand

This appliance must be installed in accordance with the Plumbing Code of Australia (PCA) and the New Zealand Building Code.

2.1 Symbols in this document

Symbol	Meaning
	This symbol indicates possible property damage, equipment damage, consequential damage or environmental damage.
	General information is identified by the adjacent symbol.
	This symbol indicates that you have to do something.
	This symbol indicates that you must fulfil certain prerequisites before you perform the following steps.
	This symbol indicates a result or intermediate result.
	These symbols indicate the software menu level (in this example level 3).
	This symbol indicates a reference to the corresponding page number (page 11 in this example).

2.2 Test mark

See type plate on the appliance.

2.3 Units of measurement

All measurements are given in mm unless stated otherwise.

3 Safety

3.1 Structure of the warning notices

3.1.1 Section-specific warning notices

Section-specific warning notices apply to all steps in the section.

Injury

CAUTION



Type and source of risk

Consequence(s) of failure to observe the warning notice

▶ Hazard prevention measure(s)

Property damage, consequential losses, environmental pollution

NOTICE



Type and source of risk

Consequence(s) of failure to observe the warning notice

Hazard prevention measure(s)



3.1.2 Embedded warning notices

Embedded warning notices apply only to the subsequent step.

▶ **SIGNAL WORD: Consequence(s) of failure to observe the warning notice. Hazard prevention measure(s).** Step to which the warning notice refers

3.1.3 Key to symbols

Symbol	Type of risk
	Injury

Symbol	Type of risk
	Electrocution
	Burns, scalding

3.1.4 Signal words

Signal word	Meaning
DANGER	Failure to observe this information will result in death or serious injury
WARNING	Failure to observe this information may result in death or serious injury
CAUTION	Failure to observe this information may result in moderate or minor injury
NOTICE	Failure to observe this information may result in property damage, consequential losses or environmental damage

3.2 Intended use

This open vented (non-pressurised) appliance is designed for heating domestic hot water. The appliance can supply one draw-off point. The appliance must only be installed with an open (non-pressurised) tap.

The product is designed for domestic use. It can be used safely by untrained persons. This product can also be used in a non-domestic environment, e.g. in a small business, as long as it is used in the same way.

Observation of these instructions and of instructions for any accessories used is also part of the intended use of this appliance.

NOTICE



Property damage

The appliance is designed for undersink installation.

- ▶ During installation, the water connections on the appliance must point upwards.

3.3 Safety instructions

- There is a risk of scalding at outlet temperatures in excess of 43 °C.
- The temperature selector should only be removed by a qualified contractor.
- Warning for Australia and New Zealand - This appliance may deliver water at high temperature. Refer to the plumbing code of Australia (PCA), local requirements and installation instructions to determine if additional delivery temperature control is required.
- Where children or persons with limited physical, sensory or mental abilities are allowed to use this appliance, we recommend a permanent temperature limit. A qualified contractor can set this limit.

Possible property damage

- Frost can destroy the appliance and the connected tap. Protect the appliance and the tap against frost.
- Warning - For continued safety of this appliance it must be installed, operated and maintained in accordance with the manufacturer's instructions.
- Never subject the appliance to water pressure. The tap outlet has a vent function. Scale build-up can block the outlet and subject the appliance to pressure.
 - Never block the tap outlet.

- Only use special aerators for non-pressurised water heaters.
- Never extend the tap outlet with a tap hose.
- Connecting the appliance via an external switching facility such as a time switch will cause an unintentional reset of the high limit safety cut-out. The appliance must not be connected to a power circuit that is regularly switched on and off by a device.

General information

- Only a qualified contractor should carry out installation, commissioning, maintenance and repair of the appliance.
- Unsuitable spare parts and accessories may jeopardise user and product safety. Always use original spare parts and original accessories.

4 Appliance description

4.1 Function

The open vented (non-pressurised) appliance is only suitable for undersink installation. The appliance is intended to heat cold water for supplying a single draw-off point. It must only be used with a non-pressurised tap.

Thermostop function

The thermostop function (thermal separation) prevents the tap becoming hot in standby mode.

4.2 Standard delivery

The following are delivered with the appliance:

- Wall mounting bracket
- Installation template

4.3 Required accessories

A non-pressurised tap must be used for open vented operation of the appliance. Stiebel Eltron offers a wide range of suitable taps.

5 Installation (qualified contractors)

5.1 Installation site

NOTICE



Property damage

The water in the appliance may freeze and damage the cylinder and connections by expansion.

- ▶ Only install the appliance in a room free from the risk of frost.

NOTICE



Property damage

- ▶ Mount the appliance on the wall. The wall must have sufficient load bearing capacity.

NOTICE



Property damage

The appliance is designed for undersink installation.

- ▶ During installation, the water connections on the appliance must point upwards.

Commissioning (qualified contractors)



Ensure that the appliance is freely accessible for maintenance work.

Always install the appliance vertically and near the draw-off point.

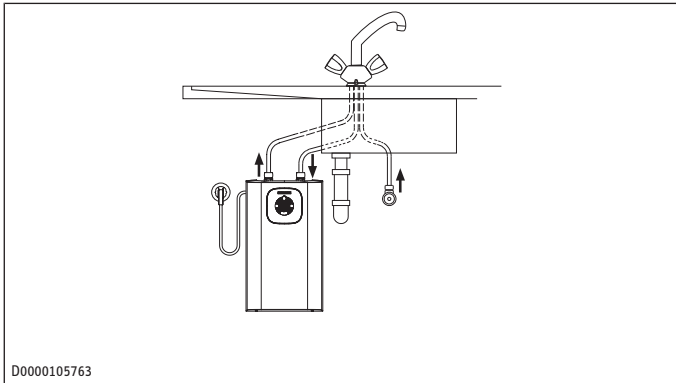

5.2 Appliance installation

- ▶ Mark out the holes for drilling using the installation template.
- ▶ Drill the holes and insert suitable rawl plugs.
- ▶ Secure the wall mounting bracket using suitable screws.
- ▶ Hang the appliance on the wall mounting bracket.
- ▶ Surplus connecting cable can be stored in the cable storage.

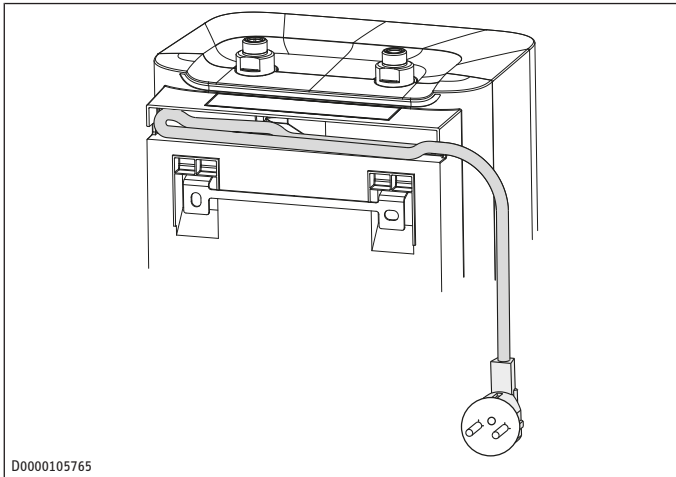

5.3 Water connection

NOTICE



Property damage

The appliance may develop a leak and cease functioning.

- ▶ Never subject the appliance to water pressure.
 - ▶ Never interchange the water connections.
 - ▶ Set the flow rate (see tap instructions). Observe the maximum permissible flow rate with a fully opened tap (see chapter "Specification / Data table").
- ▶ Match up the colour coding on the tap water connections and the appliance:
- R.h. side blue = "Cold water inlet"
 - L.h. side red = "DHW outlet"
- ▶ Secure the water connections from the tap to the appliance.

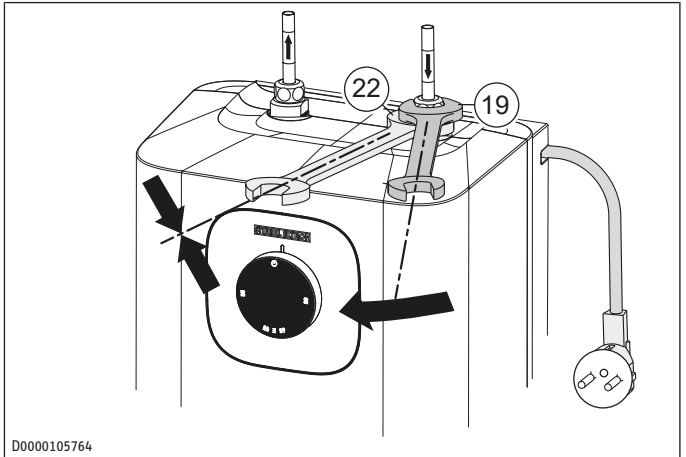

NOTICE: When tightening the fittings, counterhold with a suitable spanner.

NOTICE: Ensure that the water connections are not kinked during installation. Prevent any tensioning during installation.

6 Commissioning (qualified contractors)

NOTICE: Do not connect the power supply until the appliance is completely filled with water!

WARNING



Electrocution

Incorrect installation and commissioning can cause serious injury.

- ▶ Commissioning may only be carried out by a qualified contractor in accordance with safety regulations.

6.1 Filling the appliance with water

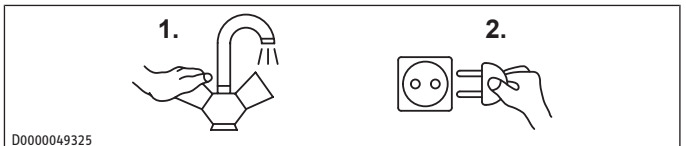

- ▶ Open the cold water inlet of the distribution board.
- ▶ Either open the DHW valve of the tap or set the mono lever mixer tap to "hot" until the water that flows out is free of air bubbles. This process may take several minutes.
- ▶ Check the entire hydraulic installation for tightness.

6.2 Electrical connection

WARNING



Electrocution when the appliance is permanently connected to the mains

When permanently connected to the power supply using a dedicated junction box, the appliance must be able to be isolated from the mains power supply by an isolator that disconnects all poles with at least 3 mm contact separation.

WARNING



Electrocution

Ensure that the appliance is connected to the earth conductor.

NOTICE



Overvoltage

The voltage specified on the type plate must match the mains power supply.

- ▶ Establish the electrical connection by plugging in the standard plug or by a permanent connection.

The following electrical connections are permissible:

	SNU 10 Plus	SNU 10 Plus (GB)	SNU 10 Plus (AU)
Connection to a freely accessible standard socket with matching plug	x		x
Permanent connection to an appliance socket with earth conductor	x	x	x

6.3 Setting a permanent temperature limit

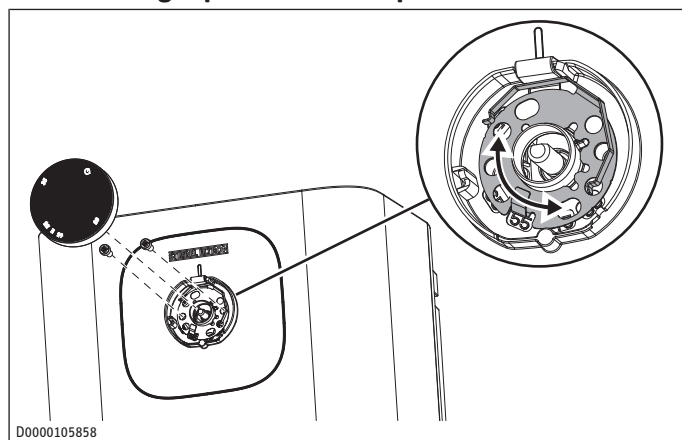

Placing the limiting ring behind the temperature selector allows you to limit the setting range of the temperature selector to a specific maximum temperature.

- ▶ Turn the temperature selector to zero (fully anti-clockwise).
- ▶ Pull off the temperature selector.
- ▶ Undo the two screws securing the limiting ring in the casing.
- ▶ Re-insert the limiting ring with the required temperature limit.
- ▶ Secure the limiting ring in the casing with the screws.
- ▶ Push the temperature selector back on its shaft in the zero position (fully anti-clockwise).

7 Operation

You can set the required hot water outlet temperature steplessly at the temperature selector (2). During the heating process, the heat-up and index indicator (1) lights up.

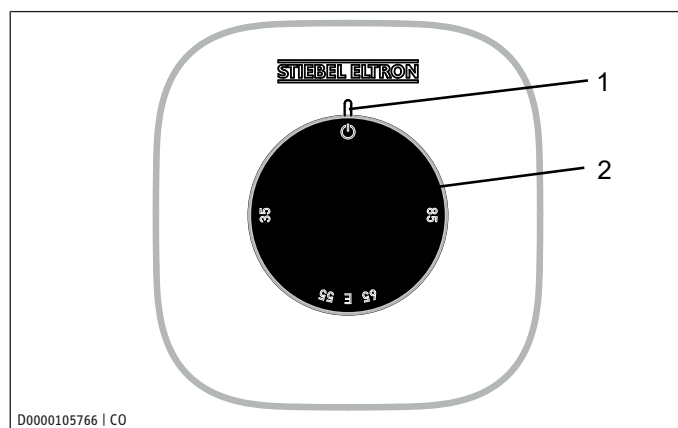

- 1 Heat-up and index indicator
- 2 Temperature selector

Depending on the system, the actual temperatures may vary from the set value.

- ⏻ On this setting, the appliance is protected from frost. The tap and the water line are not protected
- E Recommended energy saving setting ECO (approx. 60 °C), minor scaling
- 85 Highest temperature that can be set

NOTICE: The qualified contractor can set a permanent temperature limit on the appliance.

8 Cleaning

Almost every type of water will deposit limescale at high temperatures. Limescale will settle inside the appliance and affect its function and service life. The heating elements must therefore be descaled if necessary. A qualified contractor who is aware of the local water quality will tell you when the next descaling is due.

- ▶ A damp cloth is sufficient for cleaning the appliance. Never use abrasive or corrosive cleaning agents.
- ▶ Check the tap regularly. You can remove limescale deposits at the outlet using commercially available descaling agents.

9 Maintenance (qualified contractors)

WARNING



Electrocution

Risk of serious injury from an open appliance

- ▶ Before any work on the appliance, disconnect all poles of the appliance from the power supply.

- ▶ Dismantle the appliance for maintenance work.

9.1 Draining the appliance

WARNING



Burns

Hot water may escape when draining the appliance.

- ▶ Avoid all contact with escaping water.

- ▶ Isolate the appliance from the power supply.
- ▶ Undo the fittings on the water connections.
- ▶ Remove the appliance from the wall mounting bracket.
- ▶ Allow the appliance to drain into a sink with the water connections pointing downwards.

- ▶ Lightly shake the appliance to aid draining.

9.2 Opening the appliance

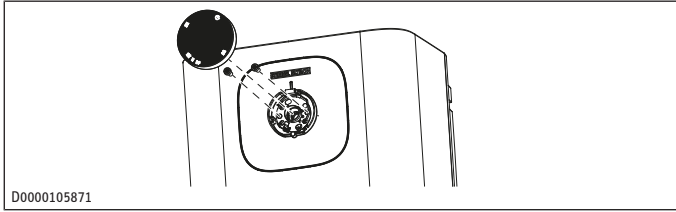

- ▶ Turn the temperature selector anti-clockwise as far as it will go.
- ▶ Pull off the temperature selector.
- ▶ Remove the two screws behind the temperature selector.
- ▶ Pull off the limiting ring.

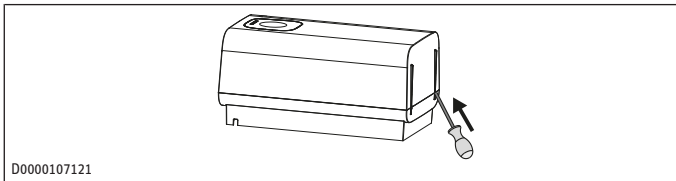

- ▶ Insert a small screwdriver into the openings at the bottom and carefully lift the appliance cover slightly.

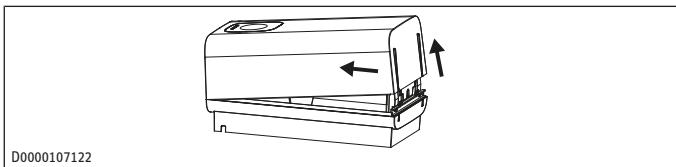

- ▶ Push and pivot the appliance cover upwards and remove it.

9.3 Descaling the appliance

NOTICE: Never treat the cylinder surface with descaling agents as these can damage the plastic.

- ▶ Open the appliance.
- ▶ Remove the flanged immersion heater.
- ▶ Carefully tap the heating element to remove coarse limescale deposits.
- ▶ Immerse the heating element up to the flange plate in descaling agent.
- ▶ Carry out descaling in accordance with the instructions provided by the descaling agent manufacturer.
- ▶ After descaling, flush the heating element with clear water. Reassemble the appliance.

9.4 Checking the earth conductor (DGVU V3)

- ▶ Pull off the temperature selector.
- ▶ Check the earth conductor (in Germany DGVU V3 for example) across a limiting ring fixing screw and the earth conductor contact of the connecting cable.

9.5 Replacing the connecting cable

NOTICE: The connecting cable must only be replaced with an original spare part by a qualified contractor.

9.6 Positioning the temperature sensor in its protective pipe

- ▶ When replacing the temperature controller, guide the temperature sensor into its protective pipe.

- ▶ Secure the temperature sensor in place below the earthed plug.

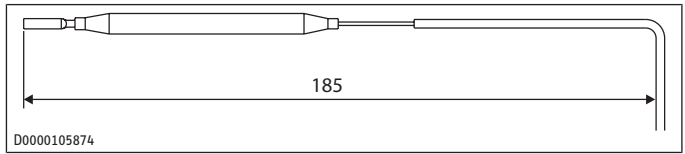

10 Troubleshooting (users)

Problem	Cause	Remedy
The appliance does not supply hot water.	The temperature selector is rotated anti-clockwise as far as it will go.	Switch the appliance on by turning the temperature selector.
	No voltage at the appliance.	Check the plug/fuses in the distribution board.
Water can only be drawn at a reduced rate.	The aerator in the tap is scaled up.	Descal/replace the aerator.
Loud boiling noises inside the appliance.	The appliance is scaled up.	Have the appliance descaled by a qualified contractor.

- ▶ If you cannot remedy the fault, contact a qualified contractor.
- ▶ To facilitate and speed up your enquiry, please provide the qualified contractor with the number from the type plate.

11 Troubleshooting (qualified contractors)

Problem	Cause	Remedy
The appliance does not supply hot water.	The high limit safety cut-out has tripped.	Remedy the cause of the fault. If necessary, replace the temperature controller. Allow the appliance to cool down. If you have isolated the appliance from the power supply, the high limit safety cut-out will be reset automatically.
Loud boiling noises inside the appliance.	The appliance is scaled up.	Descal the appliance.

12 Shutting down the system

- ▶ Isolate the appliance from the power supply by removing the plug or by switching off the MCB in the distribution board.
- ▶ Drain the appliance (see chapter *Draining the appliance* [▶ 15]).

13 Specification

13.1 Dimensions and connections of the SNU 10 Plus (all versions)

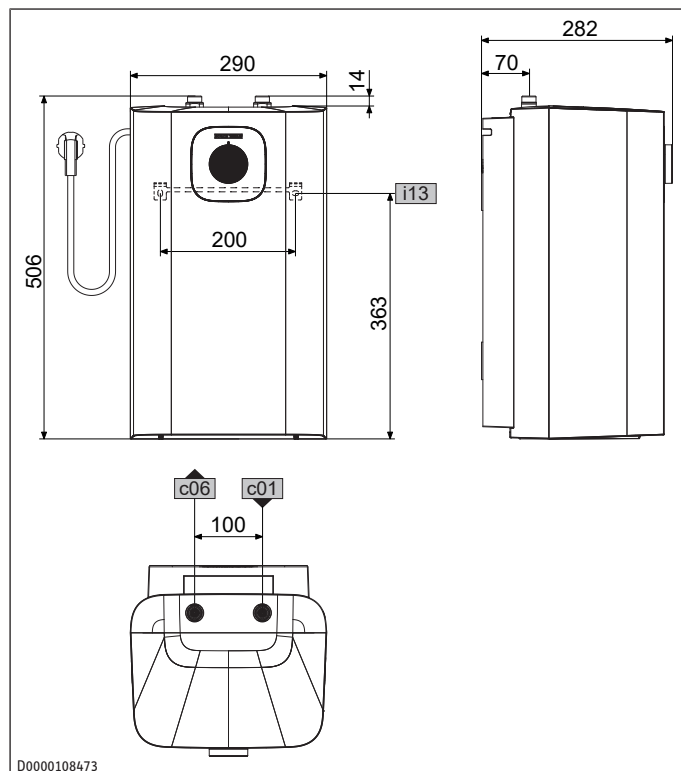

D0000108473

SNU 10 Plus			
a10	Appliance	Height	mm 506
a20	Appliance	Width	mm 290
a30	Appliance	Depth	mm 282
c01	Cold water inlet	Male thread	G 3/8 A
c06	DHW outlet	Male thread	G 3/8 A
i13	Wall mounting bracket	Height	mm 363
		Horizontal hole spacing	mm 200

13.2 Wiring diagram

1/N/PE | 220 - 240 V

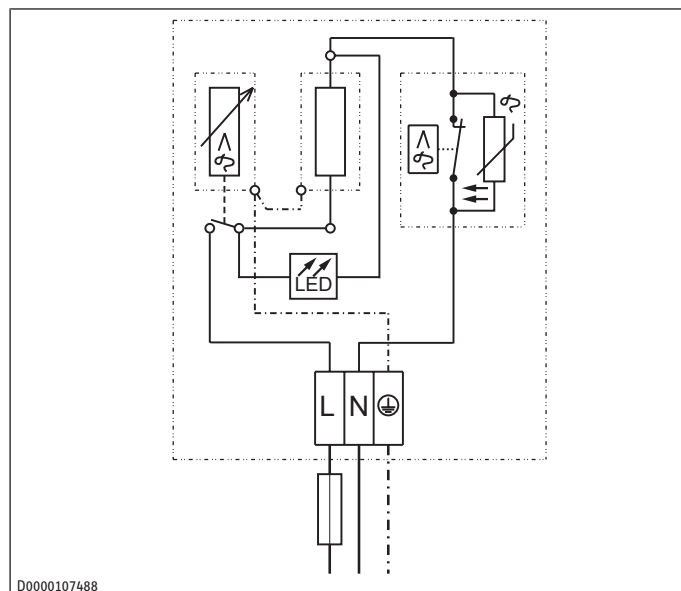

D0000107488

13.3 Heat-up diagram

The heat-up period depends on the degree of scaling and residual heat. For the heat-up time for a cold water supply at 10 °C and a maximum temperature setting, see the diagram.

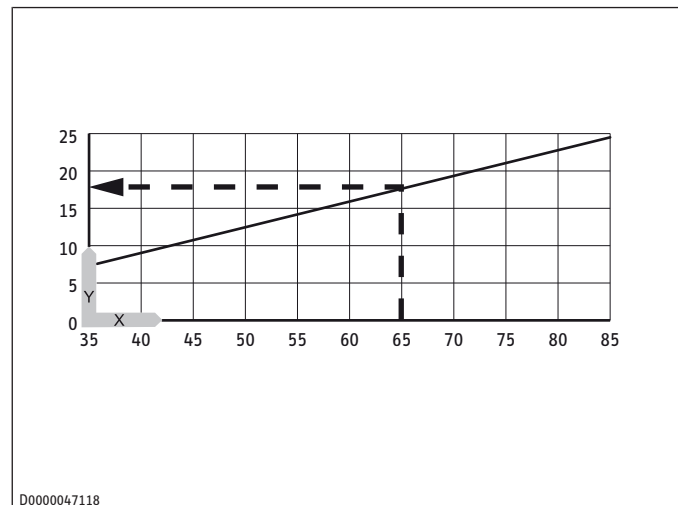

D0000047118

Y Heat-up time in minutes X Temperature in °C

Example:
Temperature setting: 65 °C
Heat-up time: approx. 18 min

13.4 Energy consumption data

The product data complies with EU regulations relating to the directive on the ecodesign of energy related products (ErP).

SNU 10 Plus (aLD)	
204980, 204981, 204982	
Manufacturer	STIEBEL ELTRON
Load profile	XXS
Energy efficiency class	A
Energy conversion efficiency	% 37
Annual power consumption	kWh 497
Default temperature setting	°C 55
Sound power level	dB(A) 15
Daily power consumption	kWh 2.310

13.5 Data table

SNU 10 Plus (aLD)	
204980, 204981, 204982	

Hydraulic data

Nominal capacity	l	10
Mixed water amount 40 °C (10 °C/65 °C)	l	19

Electrical data

Rated voltage 1	V	220
Rated voltage 2	V	230
Rated voltage 3	V	240
Rated output 1	kW	1.8
Rated output 2	kW	2.0
Rated output 3	kW	2.2
Rated current 1	A	8.3
Rated current 2	A	8.7
Rated current 3	A	9.1
Fuse protection 1	A	10
Fuse protection 1	A	10

		SNU 10 Plus (aL)
Fuse protection 1	A	10
Phases		1/N/PE
Frequency	Hz	50-60
Application limits		
Temperature setting range	°C	35 - 85 °C
Maximum permissible pressure	MPa	0.0
Maximum flow rate	l/min	10
Energy data		
Standby energy consumption/24 h at 38 °C	kWh	0.11
Standby energy consumption/24 h at 65 °C	kWh	0.31
Energy efficiency class		A
Versions		
IP rating	IP	IP 24 D
Installation type		Undersink
Type		Vented
Inner cylinder material		Plastic
Thermal insulation material		EPS
Casing material		Plastic
Colour		White
Weights		
Weight	kg	4.2

14 Guarantee

The guarantee conditions of our German companies do not apply to appliances acquired outside of Germany. In countries where our subsidiaries sell our products a guarantee can only be issued by those subsidiaries. Such guarantee is only granted if the subsidiary has issued its own terms of guarantee. No other guarantee will be granted.

We shall not provide any guarantee for appliances acquired in countries where we have no subsidiary to sell our products. This will not affect warranties issued by any importers.

15 Environment and recycling

We would ask you to help protect the environment. After use, dispose of the various materials in accordance with national regulations.

Warranty Stiebel Eltron Australia Only - According to national regulations in Australia

Stiebel Eltron Warranty for Small Water Heaters

Who gives the warranty

1. The warranty is given by Stiebel Eltron (Aust) Pty Ltd (A.B.N. 82 066 271 083) of 294 Salmon Street, Port Melbourne, Victoria, 3207 (“we”, “us” or “our”).

The warranty

2. This warranty applies to Stiebel Eltron Small Water Heaters (the “unit”).
3. Subject to the warranty exclusions we will repair or replace, at our absolute discretion, a faulty component in your unit free of charge if it fails to operate in accordance with its specifications during the warranty period.
4. If we repair or replace a faulty component to your unit under this warranty, the warranty period is not extended from the time of the repair or replacement. The repaired part will be warranted for an additional 12 months from installation or for the remaining duration of original warranty.
5. The warranty period commences on the date of completion of the installation of the unit. Where the date of completion of installation is not known, then the warranty period will commence 2 months after the date of manufacture.
6. The warranty period for a unit used for domestic purposes is shown in the table below. Domestic purposes means that the unit is used in a domestic dwelling.

Component	Warranty period
All components	5 years from the date of completion of the installation of the unit.

7. The warranty period for a unit used for commercial purposes is shown in the table below. Commercial purposes means that the unit is used for a non-domestic purpose and includes but not limited to being used in a motel, hotel, mining camp or nursing home.

Component	Warranty period
All components	1 year from the date of completion of the installation of the unit.

Your entitlement to make a warranty claim

8. You are entitled to make a warranty claim if:
 - 8.1. you own the unit or if you have the owner’s consent to represent the owner of the unit;
 - 8.2. you contact us within a reasonable time of discovering the problem with the unit.

How you make a warranty claim

9. To make a warranty claim you must provide us with the following information:
 - 9.1. The model number of the unit;
 - 9.2. A description of the problem with the unit;
 - 9.3. The name, address and contact details (such as phone number and e-mail address) of the owner;
 - 9.4. The address where the unit is installed and the location (e.g. in laundry);
 - 9.5. The serial number of the unit;
 - 9.6. The date of purchase of the unit and the name of the seller of the unit;
 - 9.7. The date of installation of the unit;
 - 9.8. A copy of the certificate of compliance when the unit was installed.
10. The contact details for you to make your warranty claim are:

Name: Stiebel Eltron (Aust) Pty Ltd
 Address: 294 Salmon Street, Port Melbourne, Victoria, 3207
 Telephone: 1800 153 351
 (8.00 am to 5.00 pm AEST Monday to Friday)

Contact person: Customer Service Representative
 E-mail: service@stiebel-eltron.com.au
11. We will arrange a suitable time with you to inspect and test the unit.

Warranty exclusions

12. We may reject your warranty claim if:
 - 12.1. The unit was not installed by registered and qualified plumber.
 - 12.2. The unit was not installed and commissioned:
 - (a) in Australia;
 - (b) in accordance with the Operating and Installation Guide; and

- (c) in accordance with the relevant statutory and local requirements of the State or Territory in which the unit is installed.
- 12.3. The unit has not been operated or maintained in accordance with the Operating and Installation Guide.
- 12.4. The unit does not bear its original Serial Number for Rating Label.
- 12.5. The unit was damaged by any or any combination of the following:
 - (a) normal fair wear and tear;
 - (b) connection to an incorrect water supply;
 - (c) connection to water from a bore, dam or swimming pool;
 - (d) connection to an incorrect or faulty power supply;
 - (e) connection to faulty equipment, such as damaged valves;
 - (f) foreign matter in the water supply, such as sludge or sediment;
 - (g) corrosive elements in the water supply;
 - (h) accidental or malicious damage;
 - (i) act of God, including damage by flood, storm, fire, lightning strike, cyclones, earthquakes, natural disasters or other similar actions of the elements;
 - (j) excessive water pressure, negative water pressure (partial vacuum) or water pressure pulsation;
 - (k) ingress of vermin.
- 12.6. The unit was damaged before it was installed e.g. it was damaged in transit.
- 12.7. An unauthorised person has modified, serviced, repaired or attempted to repair the unit without our consent.
- 12.8. Non genuine parts other than those manufactured or approved by us have been used on the unit.
13. We may charge you:
 - 13.1. for any additional transport costs if the unit is installed more than 30 kilometres from our closest authorised service technician.
 - 13.2. for the extra time it takes our authorised service technician to access the unit for inspection and testing if it is not sited in accordance with the Operating and Installation Guide and not readily accessible for inspection.
 - 13.3. for any extra costs of our authorised service technician to make the unit safe for inspection.
14. You must ensure that access to the unit by our authorised service technician is safe and free from obstruction.
15. Our authorised service technician may refuse to inspect and test the unit until you provide safe and free access to it, at your cost.
16. If we reject your warranty claim in accordance with clause 12, we may charge you for our authorised service technician’s labour costs to inspect and test the unit.
17. In order to properly test the unit we may remove it to another location for testing.

Australian Consumer Law

18. Our goods come with guarantees that cannot be excluded under the Australian Consumer Law. You are entitled to a replacement or refund for a major failure and compensation for any other reasonably foreseeable loss or damage. You are also entitled to have the goods repaired or replaced if the goods fail to be of acceptable quality and the failure does not amount to a major failure.
19. The Stiebel Eltron warranty for the unit is in addition to any rights and remedies you may have under the Australian Consumer Law.

Comfort through Technology



4 017213 532972

STIEBEL ELTRON International GmbH
Dr.-Stiebel-Straße 33 / 37603 Holzminden / Germany
info@stiebel-eltron.com / www.stiebel-eltron.com

A 353297-45112-9827