

SHP-0 200 Plus  
SHP-0 300 Plus

---

Domestic hot water heat pump 2

---



# Table of contents

---

1	Special information .....	3	15.1	Descaling the electric emergency/auxiliary heater.....	19
2	General information .....	3	15.2	Checking valves .....	20
2.1	Units of measurement .....	3	15.3	Checking consumption indicator on signal anode.....	20
2.2	Symbols in this document .....	3	15.4	Replacing the power cable.....	21
2.3	Target groups.....	3	16	Shutdown (qualified contractors) .....	21
3	Safety.....	3	16.1	Draining the DHW cylinder.....	21
3.1	Structure of the warning notices.....	3	17	Maintenance and inspection (qualified contractors) ..	21
3.2	Intended use .....	4	18	Specification .....	24
3.3	Foreseeable misuse.....	4	18.1	Dimensions and connections.....	24
3.4	Safety instructions .....	4	18.2	Wiring diagram .....	26
4	Appliance description.....	5	18.3	Data table .....	28
4.1	Standard delivery .....	5	19	Warranty .....	30
4.2	Accessories .....	5			
4.3	Function description.....	5			
5	Transportation (qualified contractors) .....	7			
6	Storage .....	8			
7	Installation (qualified contractors).....	8			
7.1	Installation site.....	8			
7.2	Siting the appliance .....	9			
7.3	Water connection .....	9			
7.4	Condensate drain .....	10			
8	Commissioning (qualified contractors) .....	10			
8.1	Filling the DHW cylinder .....	10			
8.2	Electrical connection .....	10			
8.3	Initial start-up.....	13			
8.4	Recommissioning.....	13			
9	Operation.....	14			
9.1	Display and controls.....	14			
9.2	Apps .....	14			
9.3	Pairing the heat pump with the app .....	15			
9.4	Activating/deactivating rapid heat-up.....	15			
10	Settings.....	15			
11	Cleaning .....	16			
11.1	Cleaning the casing top .....	16			
11.2	Cleaning the condensate drain .....	16			
11.3	Dissolving scale build-up .....	16			
12	Cleaning (qualified contractors) .....	16			
12.1	Cleaning the evaporator .....	16			
13	Troubleshooting .....	16			
13.1	Activating/deactivating emergency heating mode .....	18			
14	Troubleshooting (qualified contractors) .....	18			
14.1	Resetting the high limit safety cut-out .....	18			
14.2	Safety pressure limiter .....	19			
15	Maintenance (qualified contractors) .....	19			

## 1 Special information

- The appliance may be used by children over 8 years of age and persons with reduced physical, sensory or mental capabilities or a lack of experience and expertise, provided that they are supervised or they have been instructed on how to use the appliance safely and have understood the potential risks. Children must never play with the appliance. Cleaning and user maintenance must not be carried out by children without supervision.
- Observe all applicable national and regional regulations and instructions during installation.
- To prevent injury and damage, only contractors authorised by the manufacturer may replace the power cable. Use an original spare part.
- Connection to the power supply is only permitted with a suitable mains plug (not included in the standard delivery) or only as a permanent connection. Install safety equipment that allows the appliance to be separated from the power supply over an isolating distance of 3 mm. Safety equipment includes contactors, circuit breakers and fuses.
- The refrigerant used in the appliance is highly flammable (R290, propane). Only qualified refrigeration contractors holding an appropriate Australian or New Zealand license relevant to the local jurisdiction for the handling of flammable refrigerants may perform refrigeration work on the appliance.
- **WARNING – FOR CONTINUED SAFETY OF THIS APPLIANCE IT MUST BE INSTALLED, OPERATED AND MAINTAINED IN ACCORDANCE WITH THE MANUFACTURER'S INSTRUCTIONS.**
- **WARNING – THIS APPLIANCE MAY DELIVER WATER AT HIGH TEMPERATURE. REFER TO THE PLUMBING CODE OF AUSTRALIA (PCA), LOCAL REQUIREMENTS AND INSTALLATION INSTRUCTIONS TO DETERMINE IF ADDITIONAL DELIVERY TEMPERATURE CONTROL IS REQUIRED.**

## 2 General information



- ▶ Read these instructions carefully before using the appliance and retain them for future reference.



### Information for Australia and New Zealand

This appliance must be installed in accordance with the Plumbing Code of Australia (PCA) and the New Zealand Building Code.

### 2.1 Units of measurement

All measurements are given in mm unless stated otherwise.

### 2.2 Symbols in this document

Symbol	Meaning
	This symbol indicates possible property damage, equipment damage, consequential damage or environmental damage.
	General information is indicated by the adjacent symbol.
	This symbol indicates that you have to do something.
	This symbol indicates that you must fulfil certain prerequisites before you perform the following steps.
	This symbol indicates a result or intermediate result.
	These symbols show you the software menu level (in this example level 3).
	This symbol indicates a reference to the corresponding page number (page 11 in this example).

### 2.3 Target groups

#### Operator

Person without specialist expert knowledge

#### Qualified plumbing contractor

Person with specialist expert knowledge in the following areas: heating, heating media, building services, heat pump technology, occupational safety and fire safety

#### Qualified electrical contractor

Person with specialist expert knowledge in the following areas: electrical technology, occupational safety and fire safety

#### Qualified refrigeration technology contractor

Person with specialised knowledge in the following areas: electrical and refrigeration work, occupational safety and fire protection

#### Apprentice

Apprentices may only carry out the assigned tasks under professional supervision and instruction.

## 3 Safety

### 3.1 Structure of the warning notices

#### 3.1.1 Section-specific warning notices

Section-specific warning notices apply to all steps in the section.

## Injury

### CAUTION



#### Type and source of risk

Consequence(s) of failure to observe the warning notice

► Hazard prevention measure(s)

## Property damage, consequential losses, environmental pollution

### NOTICE



#### Type and source of risk

Consequence(s) of failure to observe the warning notice

► Hazard prevention measure(s)

### 3.1.2 Embedded warning notices

Embedded warning notices apply only to the step immediately following the notice.

► **SIGNAL WORD: Consequence(s) of failure to observe the warning notice. Hazard prevention measure(s).** Step to which the warning notice refers

### 3.1.3 Key to symbols

Symbol	Type of risk
	Injury
	Electrocution
	Burns, scalding

### 3.1.4 Signal words

Signal word	Meaning
DANGER	Failure to observe this information will result in death or serious injury.
WARNING	Failure to observe this information may result in death or serious injury.
CAUTION	Failure to observe this information may result in moderate or minor injury.
NOTICE	Failure to observe this information may result in property damage, consequential losses or environmental damage.

## 3.2 Intended use

The appliance is designed to heat drinking water.

The appliance is designed for indoor and outdoor installation.

The appliance is intended for domestic use. The appliance can also be used in non-domestic environments, e.g. in small businesses, as long as it is used in the same way.

Observation of these instructions, the instructions for any accessories used as well as the specifications also forms part of the correct use of this appliance.

## 3.3 Foreseeable misuse

Any other use beyond that described shall be deemed to be outside the intended use.

Heating liquids other than potable water is not permitted.

## Ambient temperatures below the application limit

If the lower application limit is undershot, the safety equipment switches the compressor off. The electric emergency/auxiliary heater takes over the DHW heating for a period of 60 minutes. After this period, the application limit is checked again. If the ambient temperature is again below the permissible temperature value, the electric emergency/auxiliary heater continues DHW heating.

## Ambient temperatures above the application limit

If the upper application limit is exceeded, the safety equipment switches the compressor off. The electric emergency/auxiliary heater takes over the DHW heating for a period of 60 minutes. After this period, the application limit is checked again. If the ambient temperature is again above the permissible temperature value, the electric emergency/auxiliary heater continues DHW heating.

## 3.4 Safety instructions

### Injury

- If the insulation or individual components are damaged, there is a risk of fatal electrocution. If such damage has occurred, switch off the power supply and arrange a repair.
- The work described in this manual requires specialised knowledge of electrical engineering and heating technology. If the work described is carried out without the appropriate expertise, this may result in injury. Only qualified contractors are permitted to work on the appliance.
- The water in the DHW cylinder can be heated to temperatures in excess of 60 °C. There is a risk of scalding at outlet temperatures in excess of 43 °C. Ensure you do not come into direct contact with the outflowing water or components that have heated up.
- If refrigerant escapes in high concentrations, it can cause symptoms such as headaches, loss of consciousness or irregular heartbeat. Avoid direct skin contact and do not inhale the vapours. Ventilate the rooms affected. Please note that refrigerants are odourless.
- The refrigerant is highly flammable. Keep the installation site clear of heat, sparks and other ignition sources, in particular in the event of a leak. The appliance may only be stored in rooms without a permanent source of ignition (e.g. naked flame, switched-on gas appliance, electric heater).
- In their original condition, electrical components are not sources of ignition (e.g. hot surface, sparking or arcing) and cannot ignite the refrigerant in the event of a leak. Only use the recommended original spare parts.
- Unsuitable spare parts and accessories may jeopardise user and product safety. Only use original spare parts and original accessories.
- Safe use is not guaranteed if installation of the appliance is incomplete. Only operate the appliance once installation is complete. Only operate the appliance with the casing and cover closed.
- **WARNING:** If the hot water unit is not used for two or more weeks, an amount of highly flammable hydrogen gas may accumulate in the water tank. To dissipate this gas safely, it is recommended that a hot tap be turned on for several minutes or until discharge of gas ceases. Use a sink, basin or bath outlet, but not a dishwasher, clothes washer or other appliance. During this procedure, there must be no smoking, open flame or any electrical appliance operating nearby. If hydrogen is discharged through the tap, it will probably make an unusual sound as with air escaping.

## Property damage, consequential losses, environmental pollution

- Poor air quality can damage the appliance. Keep the appliance installation site free from air contaminated with oil or salt (chloride). Keep the installation site free from corrosive and explosive substances. Avoid contaminating the installation site with dust, hairspray or substances containing chlorine or ammonia.
- If the air supply is restricted, the operational reliability of the appliance cannot be guaranteed. Never cover the appliance.
- The appliance may be damaged if the DHW cylinder is empty and the appliance is switched on. Only operate the appliance when the DHW cylinder has been filled.
- Hoses and insulation may be damaged if laid incorrectly. Avoid kinking or excessively compressing hoses and insulation.

## Emergency shutdown

- ▶ Interrupt the power supply by removing the fuse or switching off the supply isolation switch/ miniature circuit breaker (MCB) or by unplugging the appliance.
- ▶ Close the cold water inlet.

## 4 Appliance description

### 4.1 Standard delivery

- 1× condensate drain bend
- 1× T&P relief valve Rp $\frac{1}{2}$
- 2× straight pipe adaptors from G1 to Rp $\frac{3}{4}$
- 2× insulation sleeves
- 2× insulating hose with aluminium laminate, pre-installed

### 4.2 Accessories

#### 4.2.1 Required accessories

Various safety valves are available depending on the water supply pressure. These safety valves protect the appliance against unacceptable excess pressure.

### 4.3 Function description

The appliance is an air source heat pump with auxiliary heating and passive defrost operation and supplies several draw-off points with domestic hot water.

#### Function

There is a closed circuit within the heat pump which contains refrigerant.

- The heat pump extracts heat from the ambient air, which is transferred to the refrigerant in the refrigerant circuit inside the evaporator.
- The evaporator heats the refrigerant further so that it changes from a liquid to a gaseous state.
- The compressor draws in the gaseous refrigerant and compresses it. This increase in pressure raises the refrigerant temperature.
- In the downstream condenser, the refrigerant then transfers heat to the DHW cylinder. The refrigerant changes to a liquid state.
- The liquid refrigerant flows through an expansion valve, which reduces the pressure and temperature of the refrigerant.
- The cycle begins again.

- When a DHW draw-off point is opened, cold incoming water forces the domestic hot water out of the appliance.

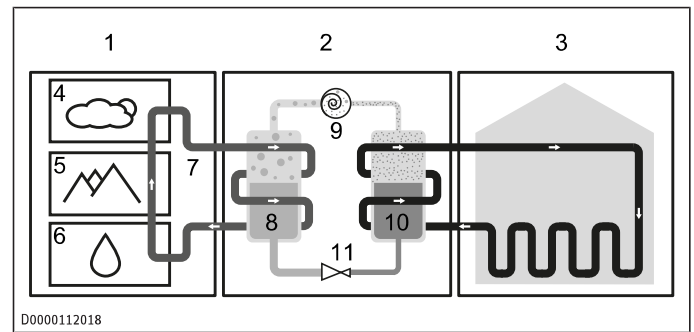

- |  |                                   |
|--|-----------------------------------|
| 1 Heat source                                | 2 Heat pump (refrigerant circuit) |
| 3 Heat distribution system (heating circuit) | 4 Air                             |
| 5 Ground                                     | 6 Water                           |
| 7 Environmental energy                       | 8 Evaporator                      |
| 9 Compressor                                 | 10 Condenser                      |
| 11 Expansion valve                           |                                   |

The lower the temperature of the intake air and the higher the selected set temperature, the longer the heat-up time. The heating output of the heat pump drops and the demand for electrical energy increases.

#### Appliance design

The heat pump unit is located in the upper section of the appliance.

The heat pump is controlled electronically.

Subject to the power supply and your draw-off patterns, the heat pump automatically heats water to the selected set temperature.

The DHW cylinder is located in the lower section of the appliance. To protect against corrosion, the DHW cylinder is coated internally with special enamel and equipped with a protective anode.

SHP-O 200 Plus:

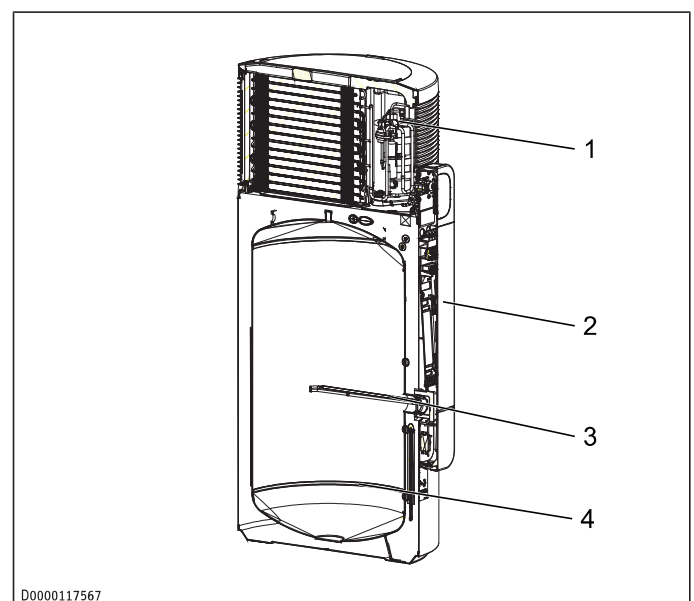

- |                    |                                       |
|--------------------|---------------------------------------|
| 1 Heat pump unit   | 2 Control panel with programming unit |
| 3 Auxiliary heater | 4 DHW cylinder                        |

SHP-O 300 Plus:

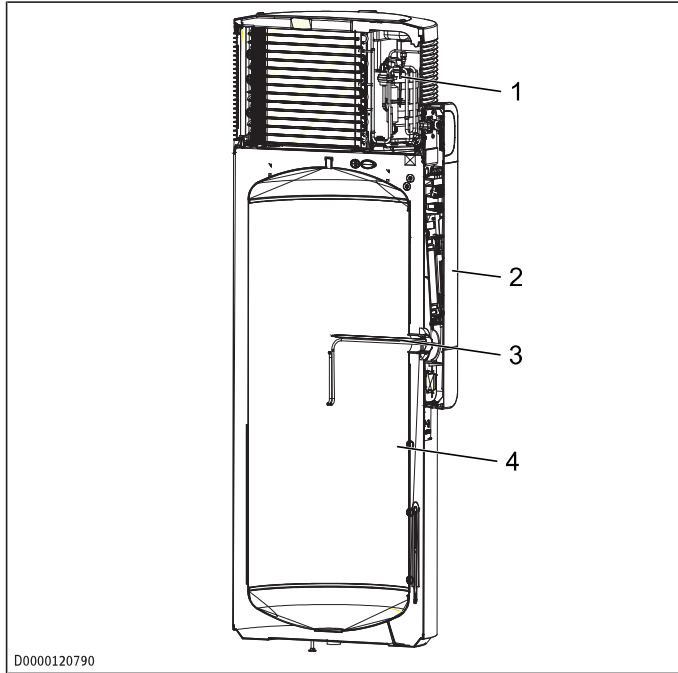

D0000120790

- |                    |                                       |
|--------------------|---------------------------------------|
| 1 Heat pump unit   | 2 Control panel with programming unit |
| 3 Auxiliary heater | 4 DHW cylinder                        |

### 4.3.1 DHW heating

The appliance is equipped with two temperature sensors.

- The cylinder top sensor captures the water temperature in the upper section of the cylinder.
- The integral sensor determines the average cylinder temperature.

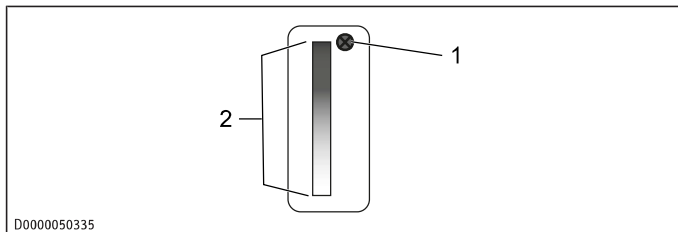

D0000050335

- |                       |                   |
|-----------------------|-------------------|
| 1 Cylinder top sensor | 2 Integral sensor |
|-----------------------|-------------------|

The MyStiebel app displays the temperature in the upper section of the cylinder, which is captured by the cylinder top sensor. The control unit additionally uses the average cylinder temperature captured by the integral sensor.

DHW heating starts in the following cases:

- The actual temperature determined by the cylinder top sensor is  $\geq 3$  K lower than the set temperature.
- The available mixed water amount drops to the percentage share of the maximum mixed water amount set in the parameter "charge level". The available mixed water amount is calculated on the basis of the average cylinder temperature. The mixed water amount is only calculated if the water temperature in the upper and middle section of the cylinder is higher than  $40\text{ }^{\circ}\text{C}$  ( $\pm 0.5$  K).
- In addition, a daily heating cycle is automatically applied for hygienic safety.

### 4.3.2 Defrost monitoring

The appliance is equipped with an electronic defrost monitor.

Low air intake temperatures may result in the formation of hoar frost on the evaporator depending on the air humidity and DHW temperature.

The appliance starts the defrosting process when the air intake temperature and the evaporator temperature fall below the set limits.

During the defrosting process, DHW heating with the heat pump (compressor) is interrupted. If the electric emergency/auxiliary heater was already activated, it remains active.

In the MyStiebel app, it is possible to activate the electric emergency/auxiliary heater to heat the water.

If it is necessary to defrost the evaporator, the heat-up processes will take longer.

The appliance switches off the compressor during the defrosting process. The fan continues to run.

The defrosting process is shown in the MyStiebel app until it finishes.

### 4.3.3 Frost protection / holiday

The operating modes must be activated in order to use the functions.

The appliance activates a frost protection function if the DHW temperature is below a limit value ( $< 8\text{ }^{\circ}\text{C}$ ).

The appliance heats the water with the heat pump. If the temperature falls below the application limit or the temperature in the DHW cylinder drops, the electric emergency/auxiliary heater is switched on.

The heat pump and electric emergency/auxiliary heater switch off once the DHW temperature is above the limit value again.

### 4.3.4 Electric emergency/auxiliary heater

Water is normally heated by the heat pump of the appliance.

If the temperature falls below or exceeds the application limits, the electric emergency/auxiliary heater takes over DHW heating to the set temperature. Heat pump operation is interrupted. Every hour, the control unit once again checks whether the application limits are being adhered to.

Once the appliance is operating within the application limits again, the electric emergency/auxiliary heater switches off and DHW heating continues with the heat pump.

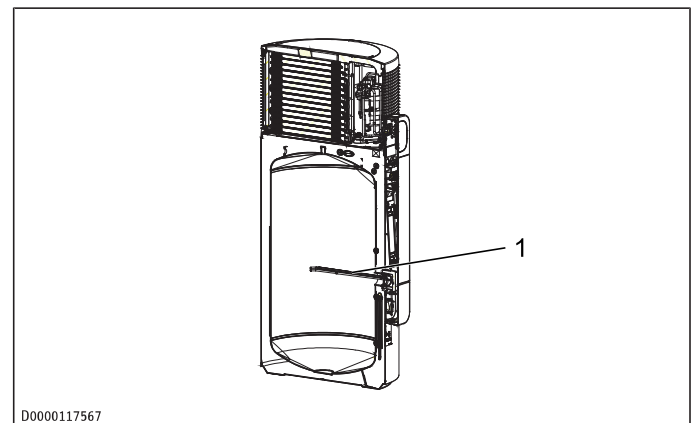

D0000117567

- |                                       |
|---------------------------------------|
| 1 Electric emergency/auxiliary heater |
|---------------------------------------|

### Emergency heating mode

Emergency heating mode can be used to start up the electric emergency/auxiliary heater (see chapter *Activating/deactivating emergency heating mode* [► 18]).

## Rapid/comfort heat-up

If a one-off demand for extra hot water arises, you can activate this function (see chapter *Activating/deactivating rapid heat-up* [▶ 15]).

### 4.3.5 External signal transmitter

External signal transmitters can be integrated via the built-in contact input, e.g. a photovoltaic system to make use of solar power generated on site.

### 4.3.6 External switching device

The device can be operated with an external switching device that interrupts the power supply to the appliance. This can be, for example:

- External time switch
- Switched socket
- Energy management system
- Signal from the power supply utility (EVU) that interrupts the power supply

### 4.3.7 Time-dependent boost

Only use the time-dependent boost function if instructed to do so by STIEBEL ELTRON. Activating this function is likely to affect the efficiency of the appliance and can lead to unnecessarily higher energy consumption and higher operating costs.

The appliance offers the option of a time-dependent boost heat-up. If the selected set temperature is not reached by the heat pump after a user defined period, the appliance switches on the electric emergency/auxiliary heater in parallel to back up the heat pump (subject to this function being enabled).

Once the set temperature has been reached, the electric emergency/auxiliary heater is deactivated until the set runtime has elapsed again following a heat demand. This function is disabled at the factory.

## 5 Transportation (qualified contractors)

Observe the following information:

- The appliance has a high centre of gravity and low overturning moment.
  - The appliance casing is not designed to withstand strong forces.
  - The appliance is easier to transport in its packaging than unpacked.
- ▶ Observe the transport information on the back part of the box.
- ▶ Transport the appliance in dry conditions and at temperatures between 0°C and +45°C.
- ▶ Transport the appliance vertically. You can transport the appliance horizontally for a short time (max. 24 hours) on flat, smooth roads. In this case, lie the appliance on its back.

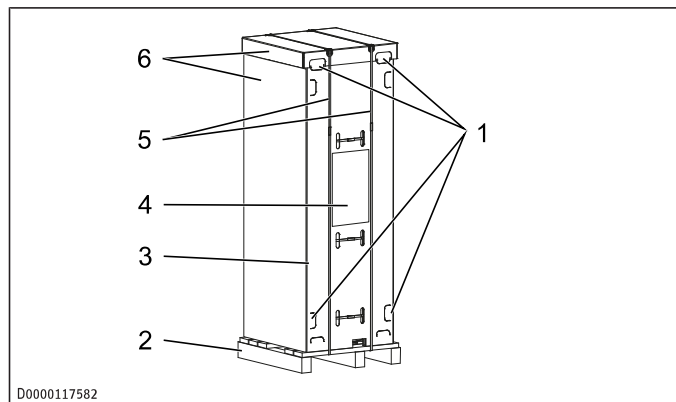

- |                        |                         |
|------------------------|-------------------------|
| 1 Recessed grips       | 2 Pallet                |
| 3 Back part of the box | 4 Transport information |
| 5 Vertical straps      | 6 Cardboard sleeve      |

### Transporting the appliance in its box on a pallet

- ▶ Use the recessed grips and the bottom section of the pallet to carry the appliance.

### Only transport appliance with cardboard back panel on a pallet

- ▶ Cut the vertical straps.
- ▶ Remove the cardboard sleeve from the appliance.
- ▶ Carry the appliance to its installation site by the recessed grips.

### Only transport appliance with cardboard back panel without a pallet

- ▶ Cut the vertical straps.
- ▶ Remove the cardboard sleeve from the appliance.

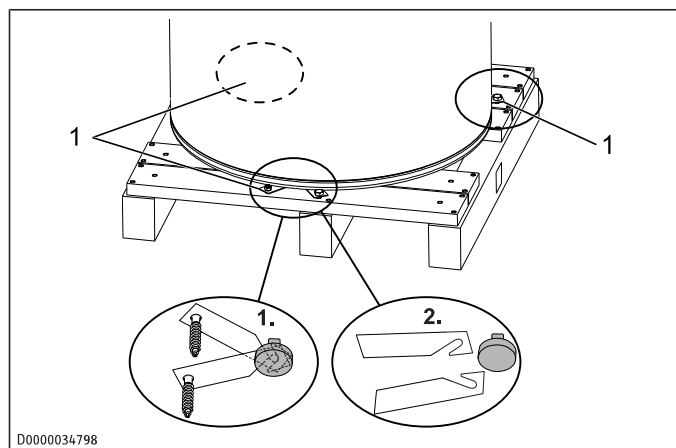

- 1 Metal bracket with screw
- ▶ Remove the screws from all metal brackets on the pallet.
- ▶ **WARNING: Sharp edges on the metal brackets can cause cutting injuries.** Handle the metal brackets with care.
- ▶ Push the metal brackets towards the centre of the appliance to unhook them from the appliance feet.
- ▶ Pull the metal brackets out from underneath the appliance.
- ▶ **WARNING: If the appliance is tilted too far, it may tip over and cause injury. Take note of the appliance's weight and centre of gravity.** Slightly tip the appliance and carefully roll it off the pallet.
- ▶ Carry the appliance to its installation site by the recessed grips.

## 6 Storage

Store the appliance

- Vertically
- Dry
- Dust-free
- Free from aggressive substances
- Covered (if it has been unpacked)
- at temperatures between 0 °C and +45 °C

## 7 Installation (qualified contractors)

### 7.1 Installation site

#### Property damage, consequential losses, environmental pollution

- Observe the need for a properly drained safe-tray under the appliance where leakage may cause damage.

#### Appliance damage

- The installation site must be free from direct and severe weather influences.
- The air intake and air discharge must be unobstructed.
- The installation site must be well ventilated.
- The installation site must be free from flammable, highly combustible gases and substances, as well as high levels of dust.
- The substrate of the installation site must be level and have sufficient load bearing capacity. Take note of the weight of the appliance with a full DHW cylinder. If the appliance is not level, there is a risk of appliance damage.
- In the case of indoor installation, the size of the installation room must correspond to the application limits of the appliance (see chapter *Data table [▶ 28]*).
- The installation site must not be close to outdoor air conditioning units. This may impact operation and in some cases can cause damage to the appliance.
- Contaminated air can cause corrosion of copper materials in the refrigerant circuit. The evaporator may corrode, causing the appliance to fail. Do not install the appliance in areas where the following substances are present.

Impermissible substance	Example of installation site with impermissible substance
Atmospheres containing ammonia	Sewage works, pigsties
Substances which block the evaporator	Air containing oil, fat or dust (cement, flour, etc.). Notice: If the air contains hairspray (e.g. in hairdressing salons), the appliance should be operated with shorter maintenance intervals.
Saline environments	Coastal installations (< 200 m from the coast) can reduce component service life.
Atmospheres containing chlorine or chloride	Swimming pools, salt works
Atmospheres containing thermal water	
Formaldehyde in the atmosphere	Certain wood-based materials (e.g. OSB boards) Certain insulating materials (e.g. foams based on urea-formaldehyde (UF in-situ foams))

Impermissible substance	Example of installation site with impermissible substance
Carboxylic acid in the atmosphere	Extract air from kitchens Components of floor cleaners (e.g. vinegar cleaner)

#### Minimum clearances

- Leave sufficient space to provide access for installation, maintenance and cleaning. Maintain the required minimum clearances.

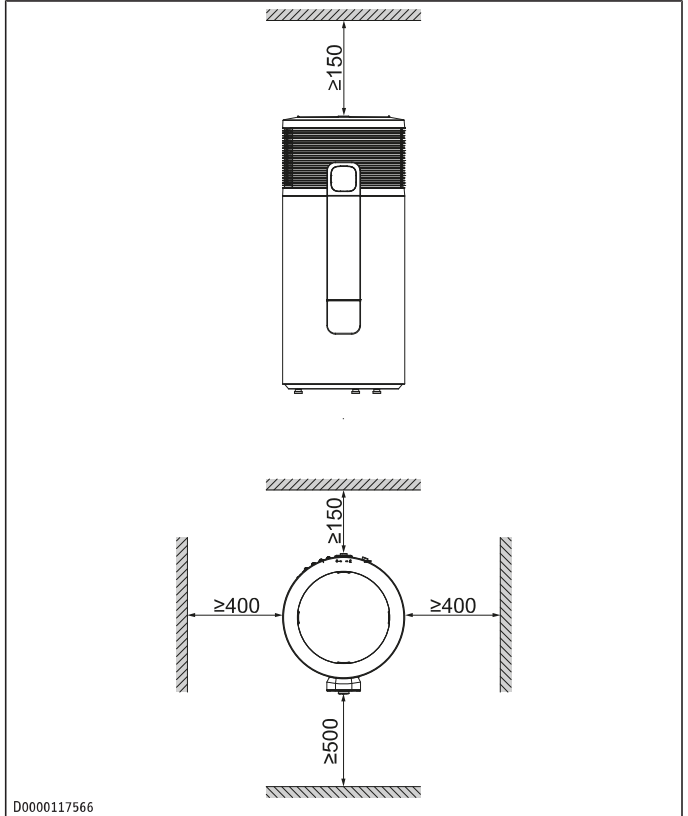

#### Efficiency

- To keep the pipe runs as short as possible, install the appliance close to kitchens or bathrooms.
- The appliance performance data is calculated according to the relevant standards, using the intake temperature specified in the data table. Below this temperature the appliance efficiency and output decrease. The heat-up time is extended.

#### Recirculation air mode

- The appliance must not impair the operation of other appliances in the installation room.
- Other appliances in the installation room must not interfere with operation of the heat pump.
- You can improve the efficiency of the appliance by utilising the waste heat from other appliances to heat the domestic hot water, e.g. boilers, tumble dryers or freezers.

#### Sound emissions

- The sound emissions are louder on the air intake and air discharge sides of the appliance than on the closed sides. Do not direct the air intake or air discharge towards noise-sensitive rooms of the house, e.g. bedrooms.
- To prevent adverse effects from operating noise, avoid installing the appliance close to bedrooms.

## 7.2 Siting the appliance

- ▶ Cut the vertical straps.
- ▶ Remove the cardboard sleeve from the appliance.

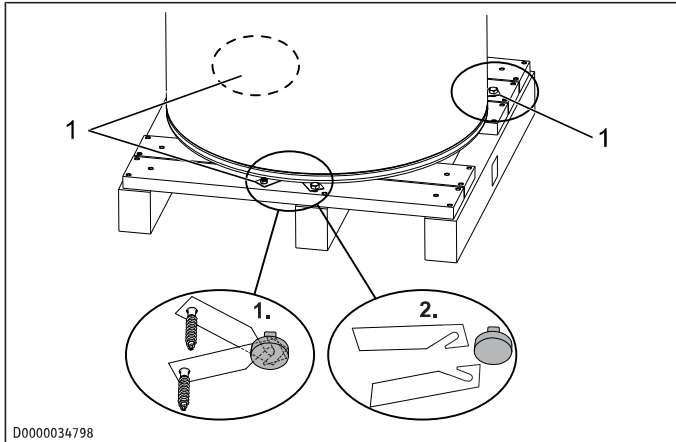

1 Metal bracket with screw

- ▶ Remove the screws from all metal brackets on the pallet.
- ▶ **WARNING: Sharp edges on the metal brackets can cause cutting injuries.** Handle the metal brackets with care.
- ▶ Push the metal brackets towards the centre of the appliance to unhook them from the appliance feet.
- ▶ Pull the metal brackets out from underneath the appliance.
- ▶ **WARNING: If the appliance is tilted too far, it may tip over and cause injury. Take note of the appliance's weight and centre of gravity.** Slightly tip the appliance and carefully roll it off the pallet.
- ▶ Position the appliance at the final installation site.
- ▶ Cut the horizontal straps.
- ▶ Remove the back part of the box from the appliance.
- ▶ Maintain the minimum clearances.

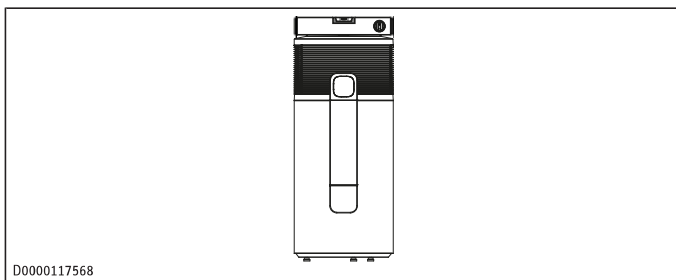

- ▶ **NOTICE: If the appliance is not positioned vertically, both the appliance and the installation site may be damaged if condensate runs out.** Level the appliance at the height-adjustable feet using a spirit level. You can place the spirit level on the support points on the casing cover.
- ▶ If required due to the local conditions, secure the appliance against tipping over in the event of an earthquake. To do this, insert metal straps through the feed-through behind the control panel.

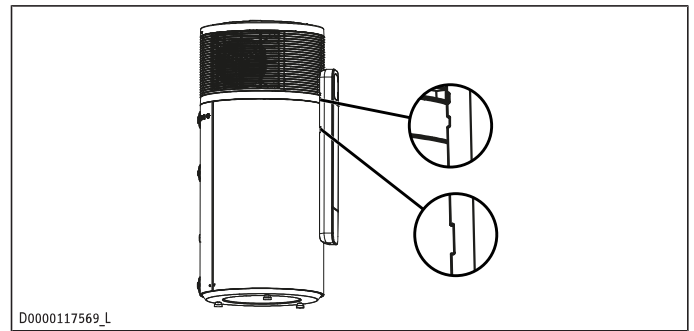

## 7.3 Water connection

- ✓ The electrical conductivity of the DHW is within the limits specified to ensure cathodic corrosion protection (see chapter *Data table* [▶ 28]).
- ✓ The cold water line is made from galvanised steel, stainless steel, copper or plastic.
- ✓ The DHW line is made from stainless steel, copper or plastic.
- ▶ Unscrew the plastic covers from the connections for the water lines. Leave the sealing plugs in the connections.
- ▶ **NOTICE: Foreign bodies, such as welding pearls, rust or sealing material, can impair the operational reliability of the appliance.** Flush the pipework thoroughly.
- ▶ Ensure that the water is free of contaminants.
- ▶ **NOTICE: To protect against corrosion, make the water connection using flat gaskets. Do not use hemp on the connections.** Connect the supplied pipes to the cold water inlet (c01) and the DHW outlet (c06). Use the insulating sleeves and union nuts for this purpose.
- ▶ Insulate the water connections to reduce heat loss and condensation.
- ▶ Install a temperature and pressure relief valve.
- ▶ Install a cold water expansion valve if this is required by local regulations.

### Temperature and pressure relief valve

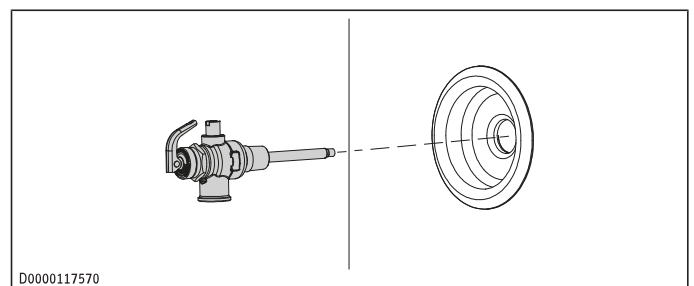

- ▶ Size the drain pipe so that water can drain off unimpeded when the temperature and pressure relief valve is fully opened.
- ▶ Hot expansion water escapes from the temperature and pressure relief valve. Ensure that expansion water can drip into a drain, e.g. a tank, funnel or tundish.
- ▶ Ensure that the drain pipe of the temperature and pressure relief valve is open to the atmosphere.
- ▶ Route the drain pipe of the temperature and pressure relief valve with a constant fall in a room free from the risk of frost.
- ▶ Install a temperature and pressure relief valve (850 kPa) at connection c13.

## Cold water expansion valve

- ▶ Size the drain pipe so that water can drain off unimpeded when the cold water expansion valve is fully opened.
- ▶ Ensure that the drain pipe of the cold water expansion valve is open to the outside.
- ▶ Lay the drain pipe of the cold water expansion valve with a constant fall in a room free from the risk of frost.
- ▶ Expansion water is discharged from the cold water expansion valve. Make sure that expansion water can drip into a drain, e.g. a tank or funnel.
- ▶ Install a cold water expansion valve (700 kPa) in the cold water inlet if this is required by local regulations.

## Pressure reducing valve

- ▶ The maximum pressure in the cold water inlet must be at least 20 % below the response pressure of all safety valves. If the maximum pressure in the cold water inlet is higher, install a pressure reducing valve.
- ▶ If a cold water expansion valve is installed, set the pressure reducing valve to 500 kPa.
- ▶ If a cold water expansion valve is not installed, set the pressure reducing valve to 700 kPa.

## Thermal insulation

- ▶ Insulate the DHW line and the valves in accordance with AS/NZS 3500.4. Use the insulation supplied for this purpose.
- ▶ Insulate the cold water inlet to prevent condensate forming. Use the insulation supplied for this purpose.
- ▶ Insulate the temperature and pressure relief valve with an insulating jacket (or similar).
- ▶ Insulate the adaptors for the cold water inlet and DHW outlet.

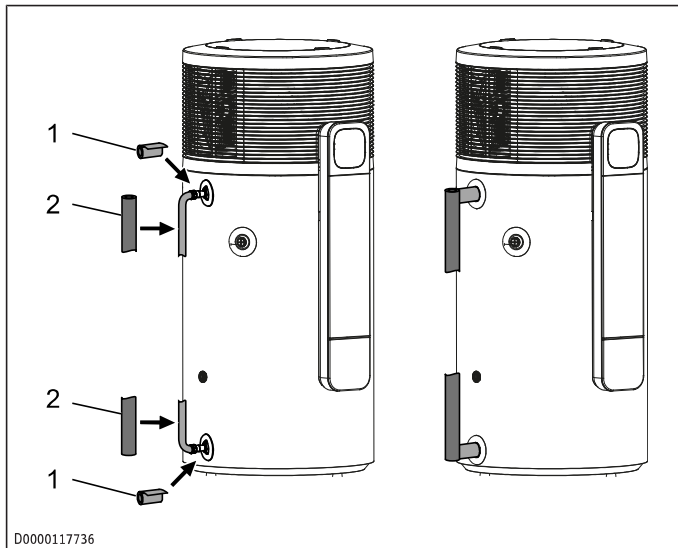

D0000117736

- |   |  |   |  |
|---|--|---|--|
| 1 | Insulation (included in the standard delivery) | 2 | Insulation (not part of the standard delivery) |
|---|--|---|--|

- ▶ Ensure that the insulation is in contact with the DHW cylinder. If necessary, shorten the insulation.

## Temperature limiter

- ▶ If necessary, install a temperature limiter in the DHW outlet, e.g. a tempering valve or thermostatic mixing valve.

## 7.4 Condensate drain

- ✓ The diameter of the condensate drain hose is larger than the diameter of the condensate drain bend.
- ▶ Connect the condensate drain bend to the connection for the condensate drain (d45).
- ▶ Connect a condensate drain hose to the condensate drain bend.

## 8 Commissioning (qualified contractors)

- ▶ If the appliance has been stored or transported horizontally, leave it to rest in an upright position for at least one hour before commissioning.

### 8.1 Filling the DHW cylinder

- ▶ To vent the pipework, open all hot water draw-off points and the shut-off valve in the cold water inlet.
- ▶ As soon as water comes out without any bubbles, close the hot water draw-off points.
- ▶ Open the temperature and pressure relief valve until water escapes.
- ▶ If installed, open the cold water expansion valve.

### 8.2 Electrical connection

- ✓ The DHW cylinder is filled.
- ▶ Install safety equipment that allows the appliance to be separated from the power supply over an isolating distance of 3 mm. Safety equipment includes contactors, circuit breakers and MCBs/fuses.
- ▶ Install a residual current device (RCD).

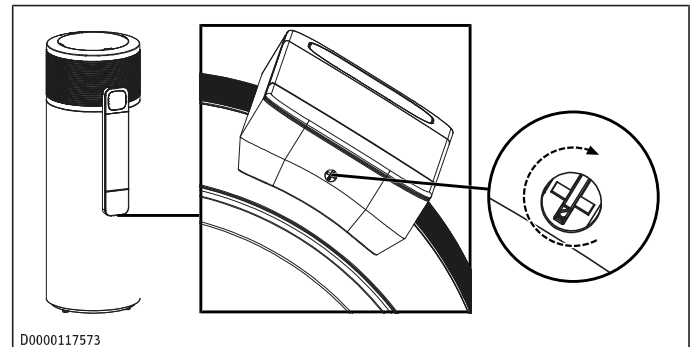

D0000117573

- ▶ Release the lock on the underside of the control panel.
- ▶ Push the control panel cover down slightly and remove it.

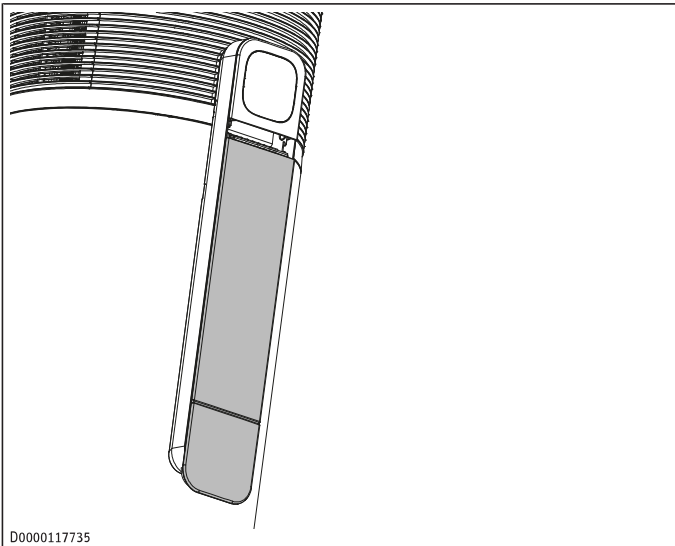

D0000117735

- ▶ If the power cable is too short, proceed as follows:
  - Disconnect the power cable in the appliance.
  - Extend or replace it with a longer power cable.
  - Route the power cable through the cable grommet such that it is watertight.
- ▶ Connect the appliance as described in the following chapter.

### 8.2.1 Standard connection without external signal transmitter

The appliance is supplied from the factory without a mains plug.

- ▶ Connect the power cables according to the following diagram.

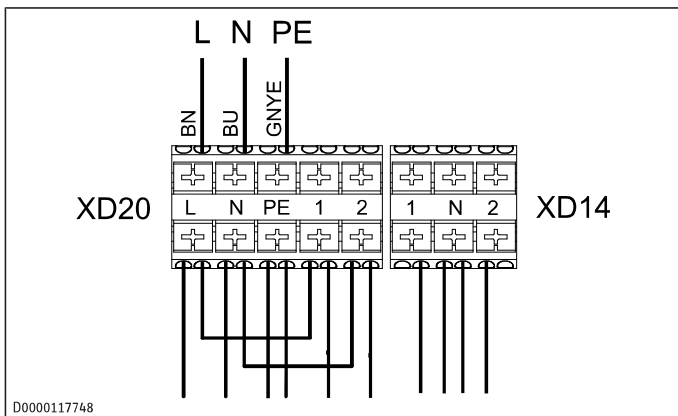

D0000117748

### 8.2.2 Connection variant: Operation with external switching device that interrupts appliance power supply

- ▶ Prepare the electric cables in such a way that each cable terminates with a wire ferrule.

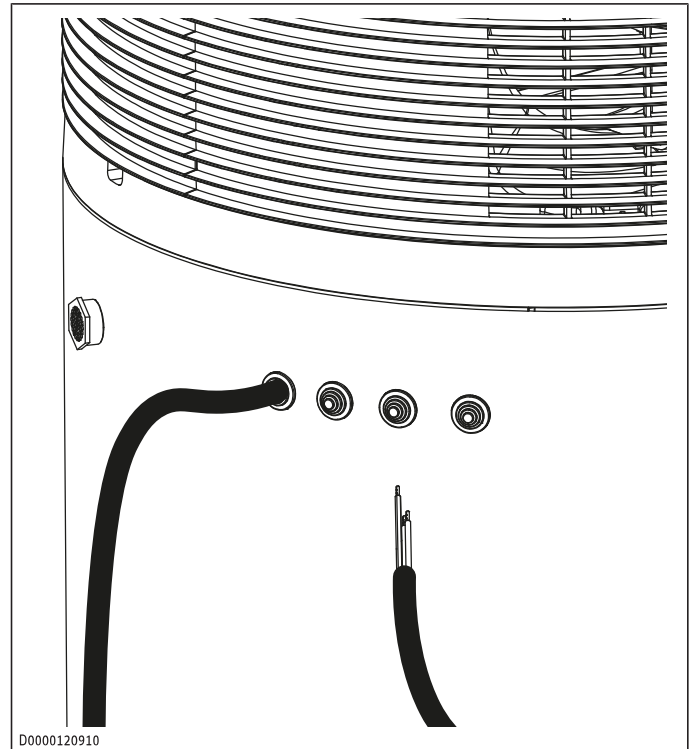

D0000120910

- ▶ Push the cables through one of the cable entries (b01) in the appliance casing.
- ▶ Route cables and leads through the strain relief fittings.
- ▶ Remove the jumper which leads from XD20/N to XD20/2 in the delivered condition.
- ▶ Remove the jumper which leads from XD20/L to XD20/1 in the delivered condition.

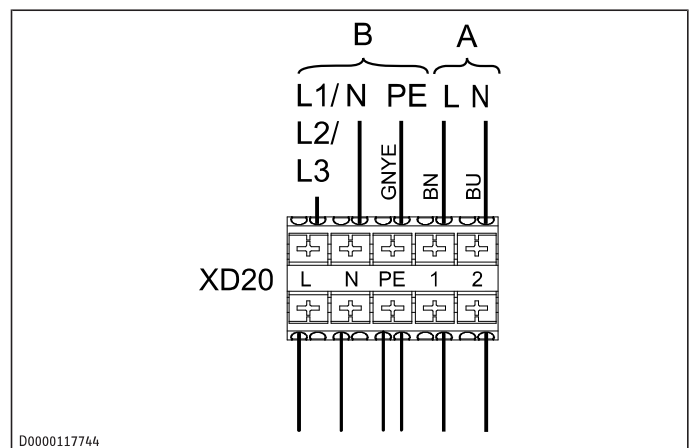

D0000117744

- A Power supply provided by power supply utility or energy management system for switching the load (compressor)
- B Power supply for the electronics

### Minimum runtime and minimum pause time

When operating with external switching devices that can interrupt the power supply to the appliance, such as time switches, energy management systems or home automation systems, the following conditions must be adhered to:

- The minimum runtime is 20 minutes.
- The minimum pause time following a shutdown is 20 minutes.
- Do not switch the appliance on or off more than 10 times a day using an external switching device.

- The contact load capacity of the switching actuator must satisfy the fuse protection requirements according to the data table.

## Closing and locking the control panel

- ▶ Replace the control panel cover.
- ▶ Lock the control panel.

### 8.2.3 Connection variant: Operation with external signal transmitter

Set temperature 1 is the standard set temperature.

Set temperature 2 is preset but inactive. If an external switching signal is present for at least one minute, set temperature 2 is activated and is valid for at least 20 minutes.

As long as the external switching signal is present, set temperature 2 remains active.

The compressor switches off when the external switching signal is cancelled or the selected set temperature is reached. The compressor remains switched off for a minimum idle time of 20 minutes. Afterwards, the selected set temperature 1 becomes higher ranking again.

Example:

- Water temperature = 55 °C
- Set temperature 1 = 61 °C
- Set temperature 2 = 65 °C

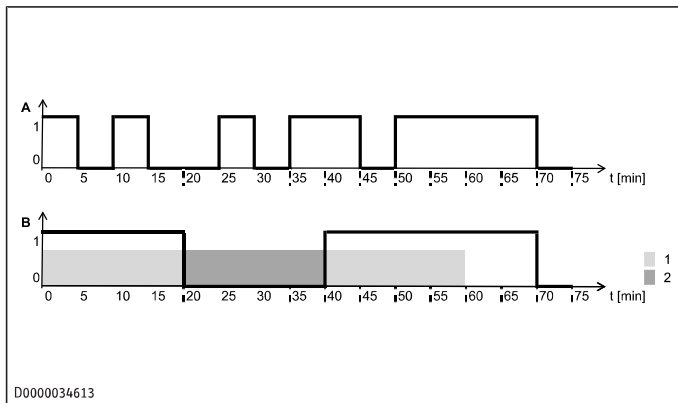

- A External signal
- B Compressor
- 1 20 min. minimum runtime, set temperature 2
- 2 20 min. minimum compressor pause time

## SG Ready

"SG Ready" is a trademark of the Bundesverband Wärmepumpe e. V. (German Heat Pump Association) and denotes a property of heat pumps whose control technology enables them to be integrated into a smart power grid (SG = Smart Grid).



The device has two contact inputs (input 1 = XD14/1, input 2 = XD14/2) for coupling to an inverter or a ripple control receiver. This enables you to integrate your connected heat pump into an intelligent power supply. Alternatively, you can utilise the device to increase the proportion of self-generated photovoltaic power.

Depending on the switching, your device can execute the following operating modes:

### SG Ready Status 1 (operating state 1)

- Input 1 = XD14/1, input 2 = XD14/2
- Switch input 1 = 0, switch input 2 = 1
- Voltage between XD14/2 and XD14/N
- Standby temperatures as specified in the operating and installation instructions for the connected heat pump (standby).
- Frost protection is assured.
- The "Standby" symbol flashes slowly.

### SG Ready Status 2 (operating state 2)

- Input 1 = XD14/1, input 2 = XD14/2
- Switch input 1 = 0, switch input 2 = 0
- Automatic / Programmed mode as specified in the operating and installation instructions for the connected heat pump.

### SG Ready Status 3 (operating state 3)

- Input 1 = XD14/1, input 2 = XD14/2
- Switch input 1 = 1, switch input 2 = 0
- Voltage between XD14/1 and XD14/N
- Forced operation with increased value for the DHW temperature (set temperature 2) (configuration in the MyStiebel app).

### SG Ready Status 4 (operating state 4)

- Input 1 = XD14/1, input 2 = XD14/2
- Switch input 1 = 1, switch input 2 = 1
- Voltage between XD14/1 and XD14/N and voltage between XD14/2 and XD14/N
- Immediate control of the maximum value (fixed) for the DHW temperature (set temperature 2) including operation of electric emergency/auxiliary heater (configuration in the MyStiebel app)

An energy management system or the power supply utility (PSU) can control the cited operating states, e.g. for load redistribution in the event of a power shortage.

If SG Ready status 1 or 4 is active, the symbol for the "SG Ready" function flashes on the appliance.

When SG Ready Status 3 is activate, the symbol for the "SG Ready" function lights up on the appliance.

## Connecting an external signal transmitter

In order to control the appliance using an external signal, you must connect a separate electric cable inside the appliance.

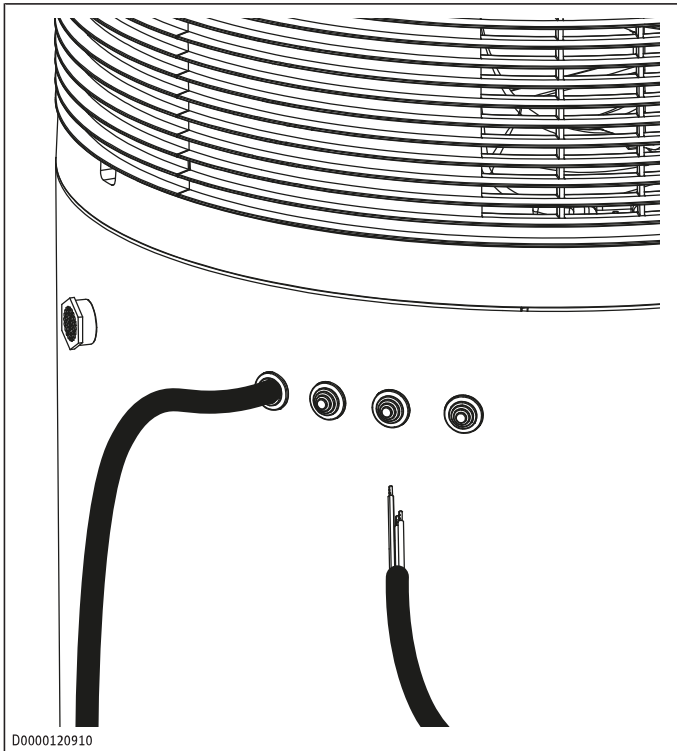

- ▶ Push the cables through one of the cable entries (b01) in the appliance casing.
- ▶ Route cables and leads through the strain relief fittings.
- ▶ **NOTICE: If the voltage is too high this can damage the appliance.** Observe the permissible voltage range for external signal transmitters.
- ▶ The table shows which terminals you need to connect to be able to map the required SG Ready status.

Terminal assignment [XD14]	Status
2 + N	SG1
no connection	SG2
1 + N	SG3
1 + N + 2	SG4

### Example 1: Switch-on signal with separate phase supply

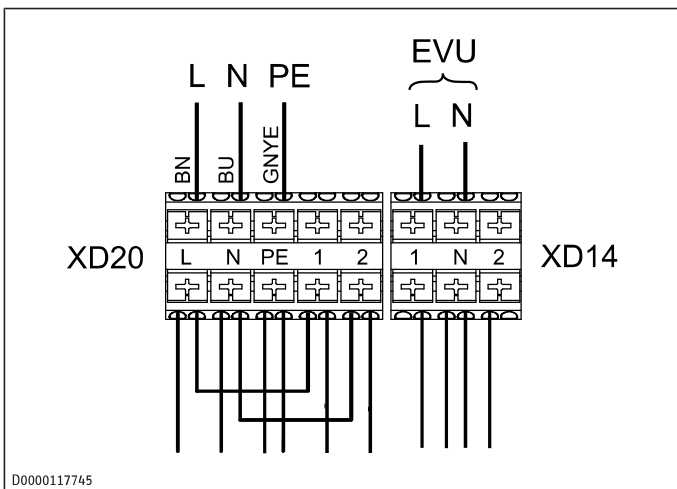

EVU Signal from the power supply utility (PSU)

### Example 2: Photovoltaic signal via on-site relay and phase routed outside the appliance

The relay in the inverter or photovoltaic system must meet the following requirements:

- Potential-free relay (240 V AC, 1 A) with N/O contact
- Adherence to safety regulations and standards for safety extra low voltage
- The switching output must be programmed such that the relay closes or opens if certain limits are exceeded or undershot (e.g. inverter output level, feed-in to the power grid).

SG Ready Status 3 is activated via the photovoltaic signal.

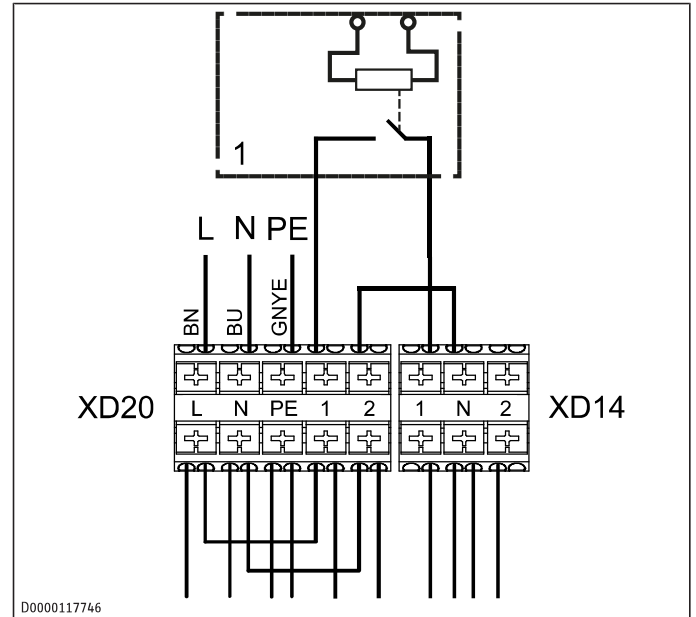

1 Inverter (floating contact)

The inverter power feed is usually located at a central distribution point (e.g. in the main fuse box).

### Closing and locking the control panel

- ▶ Replace the control panel cover.
- ▶ Lock the control panel.

### 8.3 Initial start-up

- ▶ Switch the mains power supply on.
- ▶ Check whether the heat pump heats the water.
  - ⇒ During the heat-up process, expansion water will drip from the safety valve.

### 8.4 Recommissioning

If the heat pump is switched off by an interruption to the power supply and the power supply is subsequently restored, no measures are required to restart it.

Following an interruption to the power supply, compressor operation remains blocked for at least one minute. The control delays the electrical start-up by one minute, during which the appliance initialises. If the compressor subsequently fails to start, it may be locked out by additional safety devices (motor overload relay and high pressure switch). This block should lift after 1 to 10 minutes.

The heat pump will have saved the parameters most recently set and will continue operating with them.

## 9 Operation

### 9.1 Display and controls

The appliance can be operated via an app and the buttons on the appliance.

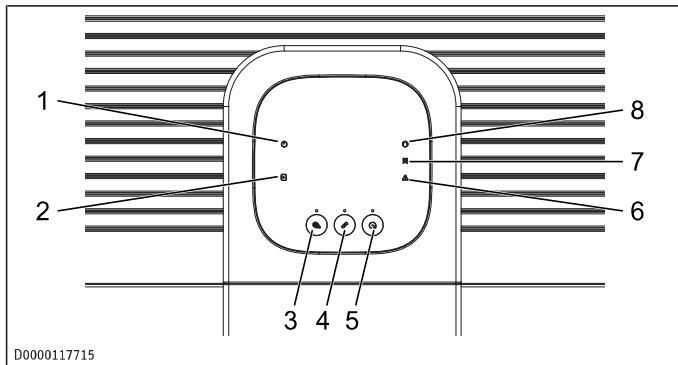

- |                                       |                    |
|---------------------------------------|--------------------|
| 1 Standby                             | 2 SG Ready         |
| 3 "Emergency mode" button             | 4 "Pairing" button |
| 5 "Rapid heat-up" button              | 6 Fault            |
| 7 Electric emergency/auxiliary heater | 8 Compressor       |

#### Symbols

Symbol	Meaning
	Compressor <ul style="list-style-type: none"> <li>- Off No heating demand to the compressor</li> <li>- Flashing Heating demand to the compressor, but the compressor is not (yet) active</li> <li>- On Compressor active or defrosting in progress</li> </ul>
	Electric emergency/auxiliary heater <ul style="list-style-type: none"> <li>- Off No heating demand to the electric emergency/auxiliary heater</li> <li>- Flashing Heating demand to the electric emergency/auxiliary heater, but the electric emergency/auxiliary heater is not (yet) active</li> <li>- On Electric emergency/auxiliary heater active</li> </ul>
	Fault <ul style="list-style-type: none"> <li>- Off No fault</li> <li>- Flashing See chapter <i>Troubleshooting</i> [▶ 16].</li> <li>- On See chapter <i>Troubleshooting</i> [▶ 16].</li> </ul>
	SG Ready <ul style="list-style-type: none"> <li>- Off No external signal</li> <li>- On SG Ready status 3 active</li> <li>- Flashing SG Ready status 1 or 4 active</li> </ul>
	Standby <ul style="list-style-type: none"> <li>- Off Appliance active, frost protection guaranteed</li> </ul>

Symbol	Meaning
- Flashing slowly	Frost protection active, SG Ready function active
- Flashing rapidly	Load shedding
- On	Frost protection active

#### LED

Button	Meaning
	Rapid heat-up <ul style="list-style-type: none"> <li>- Off Rapid heat-up inactive</li> <li>- On Rapid heat-up active</li> </ul>
	Pairing <ul style="list-style-type: none"> <li>- Off WLAN function inactive</li> <li>- Flashing slowly Access point mode requested</li> <li>- Flashing rapidly Access point mode active</li> <li>- On WLAN connection established</li> </ul>
	Emergency mode <ul style="list-style-type: none"> <li>- Off Emergency mode inactive</li> <li>- Flashing Emergency mode active</li> </ul>

#### Keypad lock

- ▶ The keypad lock can be activated and deactivated via the app.

### 9.2 Apps

You can connect the appliance directly and locally to one of our apps (MyStiebel app for operators and Servicewelt app for qualified contractors) via the integrated WLAN module. You do not need a separate internet connection for the Servicewelt app.

If the internet connection is selected in the app and permission is granted under data protection law, both apps can access the appliance from anywhere. The qualified contractor can then also access the device via the Servicewelt web portal. The Servicewelt app is the mobile extension of the Servicewelt as an internet portal.

The following functions are available with the MyStiebel app\*

- Establish a connection between a smartphone and the appliance from anywhere in the world (integration in the cloud)
- Set the temperature
- Set the heating type (efficient, balanced, fast)
- Activate/deactivate time programs
- Activate/deactivate the holiday program
- Activate/deactivate additional comfort functions (DHW Plus)
- Activate/deactivate DHW boost
- View appliance information
- View appliance errors
- Set the LED light intensity
- Lock/unlock buttons
- Activate/deactivate emergency mode
- Implement settings for use in combination with a photovoltaic system

You can use the following functions with the Servicewelt app:

- Set different operating modes (time programs, energy management)
- Set different temperatures for each operating state
- View and set various system parameters
- View current events, such as changes to parameters and system messages
- Download parameter sets and send them to STIEBEL ELTRON for analysis
- Upload previously saved parameter sets (only with confirmed customer account)
- Perform relay tests to start up the compressor and fan (only with a confirmed customer account)

The apps offer additional functionality for operators and for service and installation purposes for qualified contractors.



The appliance will operate in default factory settings once installed. Connection to the MyStiebel app and use of features is voluntary.

The appliance can be operated via an app and the buttons on the appliance.

The apps are available in the App Store® and Google Play Store™.



MyStiebel



MyStiebel



Servicewelt



Servicewelt



\*Dependent on ongoing product improvements

### 9.3 Pairing the heat pump with the app

- ✓ Secure Wi-Fi® network (802.11b/g/n/ 2.4 GHz, DHCP)
- ✓ Supported encryption methods: WPA™ PSK, WPA2™ PSK, WPA3™ PSK
- ✓ Internet connection to the mobile device
- ✓ Location sharing of the mobile device active
- ✓ Operating system of the mobile device: iOS® version 12.0 or higher, Android® version 8.0 or higher

- ✓ The requirements specified in the App Store® or Google Play Store™ for installing and using the app are satisfied
- ✓ Mobile device no more than 3 m away from the heat pump during pairing
- ✓ Proof of competence from the specialist company is required for the Servicewelt app for qualified contractors
  - ▶ Download the app to your mobile device from the Apple App Store® or Google Play Store™.
  - App for qualified contractors: Servicewelt app
  - App for operators: MyStiebel app
  - ▶ Register in the app. (Servicewelt app: If you have Servicewelt login credentials, you can use these here)
  - ▶ Grant the app the necessary authorisations.
  - ▶ Add a new appliance in the app and follow the instructions.

After the appliance has been successfully integrated into the network, communication between the appliance and the mobile end device may be restricted for several minutes. If this occurs, it does not indicate an error; any necessary software updates for the WLAN adaptor are downloaded and installed first.

Servicewelt app: Some functions of the app are not available until the specialist company has provided proof of competence.

### 9.4 Activating/deactivating rapid heat-up

#### Application

- One-off demand for extra hot water

#### Activating rapid heat-up on the programming unit

- ✓ Keypad lock is inactive.
  - ▶ Press the "Rapid heat-up" button for 2 seconds.
- ⇒ The "heat pump" and "electric emergency/auxiliary heater" symbols are shown until the function has ended. The heat pump and electric emergency/auxiliary heater are started once in parallel operation.
- ⇒ When the water temperature rises by a hysteresis value above the set temperature at the cylinder top sensor, the electric emergency/auxiliary heater is switched off (rapid heat-up). The electric emergency/auxiliary heater remains in standby mode until the set temperature has been reached throughout the DHW cylinder (comfort heat-up). A flashing "electric emergency/auxiliary heater" symbol indicates that the electric emergency/auxiliary heater is in standby mode.

#### Deactivating rapid heat-up on the programming unit

- ✓ Keypad lock is inactive.
  - ▶ To end the function prematurely, press the "Rapid heat-up" button for 2 seconds.

#### Activating and deactivating rapid heat-up in the MyStiebel app

- ▶ Activate the function in the app.
- ▶ If you want to end the function prematurely, deactivate the function in the app.

## 10 Settings

Implement the required settings in the respective app:

- App for qualified contractors: Servicewelt app
- App for operators: MyStiebel app

## 11 Cleaning

You may only use the specified cleaning agents.

Component	Interval
Casing	As required
Air intake grille	As required, every 6 months
Air outlet grille	Adapt the interval according to the air quality and the installation conditions.
Condensate drain	As required, for the first time after 1 year Adapt the interval according to the installation conditions.
Taps	As required
Safety valve	

### 11.1 Cleaning the casing top

- ▶ Clean the casing top with a cloth moistened with water.

### 11.2 Cleaning the condensate drain

- ▶ Remove the condensate drain bend.
- ▶ Remove any dirt from the connection for the condensate drain.

### 11.3 Dissolving scale build-up

Almost every type of water will deposit limescale at high temperatures. Limescale will settle inside the product and affect its function and service life.

A qualified contractor who is aware of the local water quality will tell you when the next descaling is due.

- ▶ Check the taps regularly. Use commercially available descaling agents to remove limescale from the tap spouts.
- ▶ Regularly activate the safety valve to prevent it from becoming blocked, e.g. by limescale deposits.

## 12 Cleaning (qualified contractors)

You may only use the specified cleaning agents.

Component	Interval
Evaporator	As required, for the first time after 1 year Adapt the interval according to the air quality and installation conditions.

### 12.1 Cleaning the evaporator

- ▶ Isolate the appliance from the power supply.

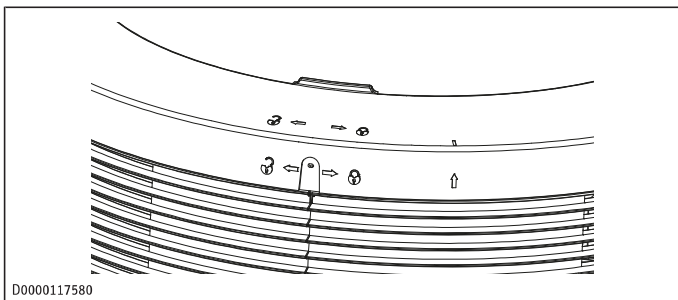

- ▶ Undo the screw at the back of the casing cover.
- ▶ To do this, turn the casing cover clockwise.
- ▶ Remove the casing cover.

- ▶ Remove the front insulation.

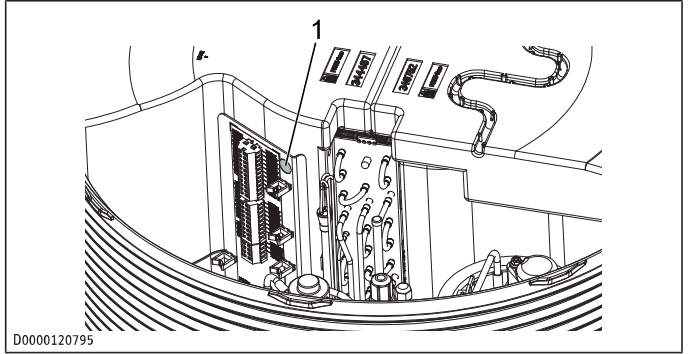

#### 1 Insulation material screw

- ▶ Remove the insulation material screw before removing the insulation on the air discharge side.
- ▶ Remove the insulation on the air intake side.
- ▶ **WARNING: The sharp-edged fins of the evaporator can cause injury. Wear protective gloves.** Clean the evaporator fins with water and a soft brush.
- ▶ Fit the insulation on the air intake side. Ensure that the temperature sensor protrudes 40 mm from the insulation.
- ▶ Fit the insulation on the air discharge side.
- ▶ Secure the insulation on the air discharge side with the insulation material screw.
- ▶ Fit the front insulation.
- ▶ Place the casing cover on the appliance.
- ▶ Turn the casing cover anti-clockwise so that it latches in place.

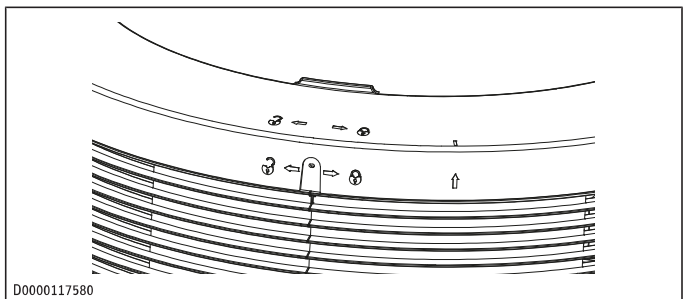

- ▶ Tighten the screw at the back of the casing cover.

## 13 Troubleshooting

- ▶ Please also observe the notifications in the MyStiebel app.

Fault	Possible cause	Remedy
The appliance does not supply hot water.	The appliance has no power.	▶ Check that the appliance is connected to the power supply.
The appliance does not supply hot water.	A fuse/MCB in the distribution board has blown/tripped.	▶ Check whether the fuses/MCBs in the distribution board have blown/tripped.

Fault	Possible cause	Remedy
		<ul style="list-style-type: none"> <li>▶ If necessary, isolate the appliance from the power supply.</li> <li>▶ Reconnect the appliance to the power supply.</li> <li>▶ Replace the fuses/reset the MCBs.</li> <li>▶ Contact a qualified contractor if the fuse/MCB blows/trips again after the appliance is connected to the power supply.</li> </ul>
The appliance does not supply hot water.	The air intake grille or air outlet grille is blocked.	▶ Remove dirt or other blockages to ensure clear intake and outlet air flows.
The appliance does not supply a sufficient quantity of DHW.	Below the application limit of the heat pump (compressor), DHW heating is taken over by the electric emergency/auxiliary heater.	No action required
The appliance does not supply hot water or the "compressor" symbol is flashing.	The temperature of the intake air is outside the application limits. The compressor was switched off/locked automatically.	No action required The appliance heats the water using the electric emergency/auxiliary heater. As soon as the temperature is back within the application limits, the heating process is continued with the compressor.
The appliance does not supply hot water.	Hot water was recently drawn off and the appliance has not yet been able to reheat the water in the DHW cylinder.	No action required ▶ Let the appliance complete the heat-up process.
The safety valve of the DHW cylinder is dripping.	The appliance cylinder is at mains water pressure. During heat-up, expansion water may drip from the safety valve.	▶ If water continues to drip after heat-up has stopped, inform a qualified contractor.
The condensate drain drips.	The surface temperature of the evaporator is lower than the dew point temperature of the ambient air. This results in condensate forming. The amount of condensate depends on the humidity level of the ambient air.	No action required

Fault	Possible cause	Remedy
The "fault" symbol is continuously illuminated.	Category 3 faults	A continuously illuminated "fault" symbol indicates that a fault has occurred, but the appliance is heating nevertheless. <ul style="list-style-type: none"> <li>▶ Notify a qualified contractor. The qualified contractor can find more information on troubleshooting in the Servicewelt app.</li> </ul>
The "fault" symbol flashes.	The compressor is locked out.	A flashing "fault" symbol indicates that a fault has occurred, but the appliance is heating nevertheless. <ul style="list-style-type: none"> <li>▶ Notify a qualified contractor. The qualified contractor can find more information on troubleshooting in the Servicewelt app.</li> </ul>
The compressor is switched off; the fan continues to run. The "compressor" symbol is shown.	The appliance is in defrost mode.	No action required
The "compressor" symbol is flashing.	There is a heat demand, but the compressor is locked out.	No action required The compressor restarts automatically after the compressor lockout time has elapsed. The symbol stops flashing automatically.
The "electric emergency/auxiliary heater" symbol is flashing.	A temperature controller has switched off the electric emergency/auxiliary heater during rapid heat-up.	No action required The appliance continues the rapid heat-up process using the heat pump. When the controller enables the electric emergency/auxiliary heater again, the symbol stops flashing. The symbol goes out when the temperature throughout the DHW cylinder reaches the set rapid heat-up temperature.
The "electric emergency/auxiliary heater" symbol is illuminated but the electric emergency/auxiliary heater is not active.	The electric emergency/auxiliary heater lights up when there is a demand. The internal controller of the electric emergency/auxiliary heater may have ended electric heating. A possible cause may be a fault in the electric emer-	▶ Notify a qualified contractor.

Fault	Possible cause	Remedy
	gency/auxiliary heater. A possible cause may be that the high limit safety cut-out has responded.	

- ▶ If you cannot remedy the fault, contact STIEBEL ELTRON.
- ▶ To facilitate and speed up your enquiry, please provide STIEBEL ELTRON with the number from the type plate.

The type plate is located next to the power cable.

### Example type plate

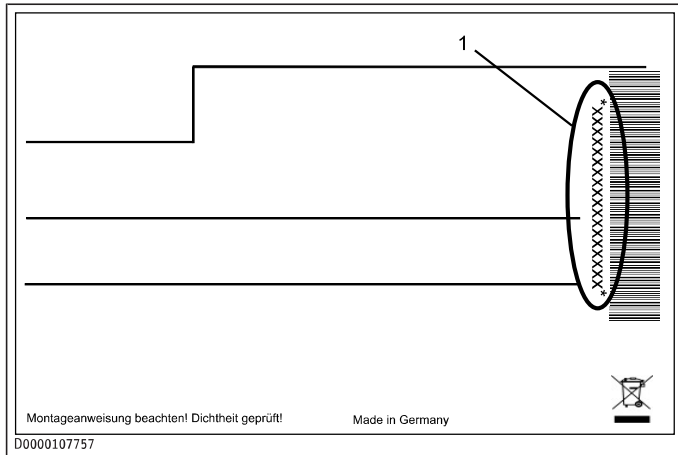

1 Number on the type plate

## 13.1 Activating/deactivating emergency heating mode

### Activating emergency heating mode

- ✓ Keypad lock is inactive.
- ▶ Press the "Emergency mode" button on the programming unit for 2 seconds. Alternatively, activate emergency mode in the MyStiebel app.
  - ⇒ The current set temperature is ignored. In emergency heating mode, the appliance operates with a fixed set temperature. In the upper cylinder section, the DHW is heated up to 65 °C by the electric emergency/auxiliary heater.
  - ⇒ Emergency heating mode remains activated for 7 days.
- ▶ If you want to extend emergency heating mode by a further 7 days, press the "Emergency mode" button again. Alternatively, extend the emergency mode time in the MyStiebel app.
  - ⇒ From this point on, emergency heating mode remains activated for 7 days.

### After a power interruption

Emergency heating mode remains active after an interruption to the power supply.

### Deactivating emergency heating mode

- ✓ Keypad lock is inactive.
- ▶ Press the "Emergency mode" button on the programming unit for 2 seconds. Alternatively, deactivate emergency mode in the MyStiebel app.

## 14 Troubleshooting (qualified contractors)

- ▶ Please also observe the notifications in the Servicewelt app.

Fault	Possible cause	Remedy
The appliance does not supply hot water.	The appliance has no power. The power cable is damaged.	▶ Replace the power cable.
The compressor is no longer working.	The motor overload relay has responded because the temperature or current was too high for the compressor.	▶ Eliminate the cause that led the motor overload relay to respond. ⇒ After a short cooling period, the motor overload relay will restart the compressor automatically.
The compressor is no longer working.	There was no pressure equalisation in the refrigerant circuit, so the compressor is operating against a high pressure.  The electronic expansion valve is faulty.	▶ Start a calibration run in the Servicewelt app. Alternatively: ▶ Isolate the appliance from the power supply. ▶ Reconnect the power supply.

### 14.1 Resetting the high limit safety cut-out

If the temperature of the cylinder water exceeds 89 °C, the high limit safety cut-out switches off the electric emergency/auxiliary heater. These high temperatures can be caused by a defective heating element or a fault in the electronics, for example.

The high limit safety cut-out also responds in the event of frost.

- ▶ Remove the cause of the fault.
- ▶ Isolate the appliance from the power supply.

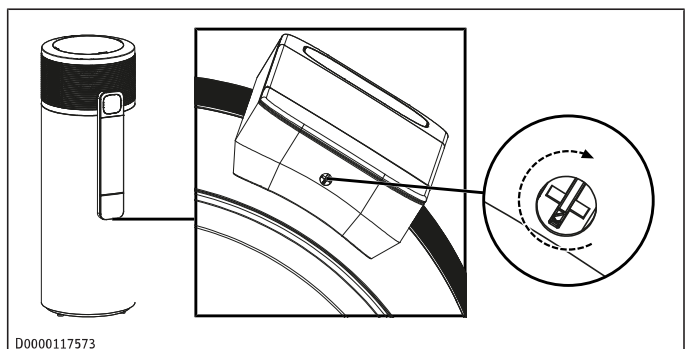

- ▶ Release the lock on the underside of the control panel.
- ▶ Push the control panel cover down slightly and remove it.

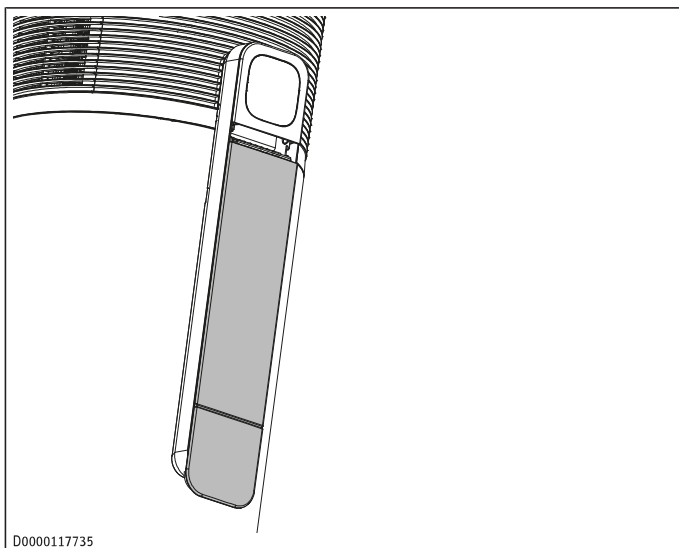

D0000117735

▶ Press the reset button on the safety cut-out.

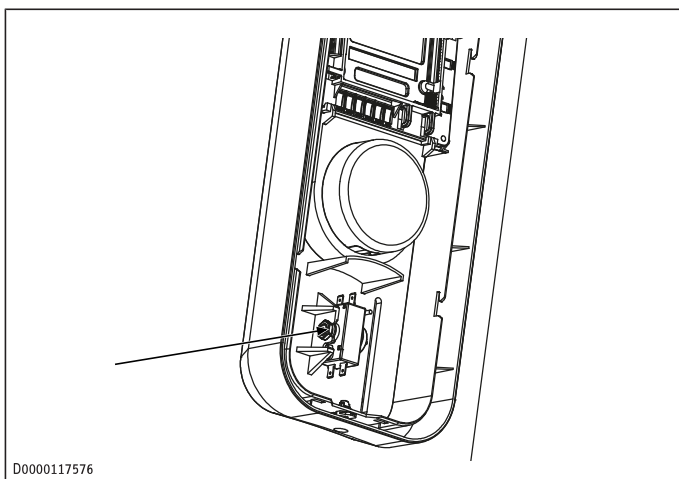

D0000117576

- ▶ If the high limit safety cut-out cannot be reset, replace it.
- ▶ Replace the control panel cover.
- ▶ Lock the control panel.
- ▶ Reconnect the appliance to the power supply.

## 14.2 Safety pressure limiter

If the pressure in the refrigerant circuit is too high, the safety pressure limiter interrupts the power supply to the compressor until the pressure in the refrigerant circuit falls below the set limit value. If the safety pressure limiter responds 5 times in 5 hours, compressor operation is blocked.

- ▶ Remove the cause of the fault.
  - ⇒ The appliance carries out pressure equalisation. This process takes a few seconds.
- ▶ When the pressure equalisation process is complete, unlock the heat pump in the Servicewelt app.

## 15 Maintenance (qualified contractors)

You may only carry out maintenance work as described here.

Component	Activity	Interval
Electric emergency/auxiliary heater	Descale the emergency/auxiliary heater to increase its service life.	For the first time after 1 year As required

Component	Activity	Interval
		If necessary, shorten the interval depending on the water quality and the installation conditions.
Condensate drain	Check that the condensate drain is clear.	For the first time after 1 year As required
		If necessary, shorten the interval depending on the installation conditions.
Evaporator	Check the evaporator.	For the first time after 1 year As required
		If necessary, shorten the interval depending on the air quality and the installation conditions.
Valves (safety valve, pressure reducing valve, drain valve)	Check the valves for limescale deposits and damage.	For the first time after 1 year As required
		If necessary, shorten the interval depending on the water quality and the installation conditions.
Signal anode	Check the consumption indicator.	For the first time after 2 years As required
		If necessary, shorten the interval depending on the water quality and degree of wear.

## 15.1 Descaling the electric emergency/auxiliary heater

- ▶ Isolate the appliance from the power supply.
- ▶ Empty the DHW cylinder to below the flange for the electric emergency/auxiliary heater (> 130 litres) (see chapter *Draining the DHW cylinder* [▶ 21]).

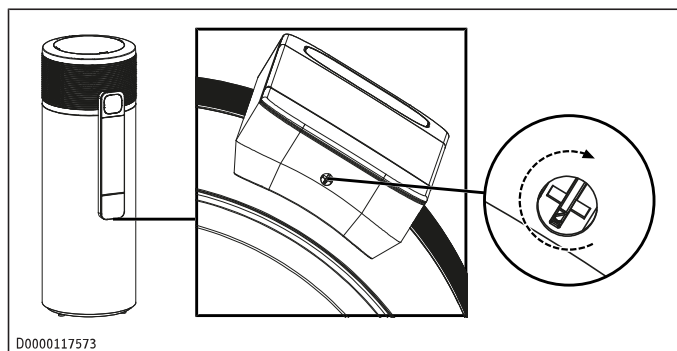

D0000117573

- ▶ Release the lock on the underside of the control panel.
- ▶ Push the control panel cover down slightly and remove it.

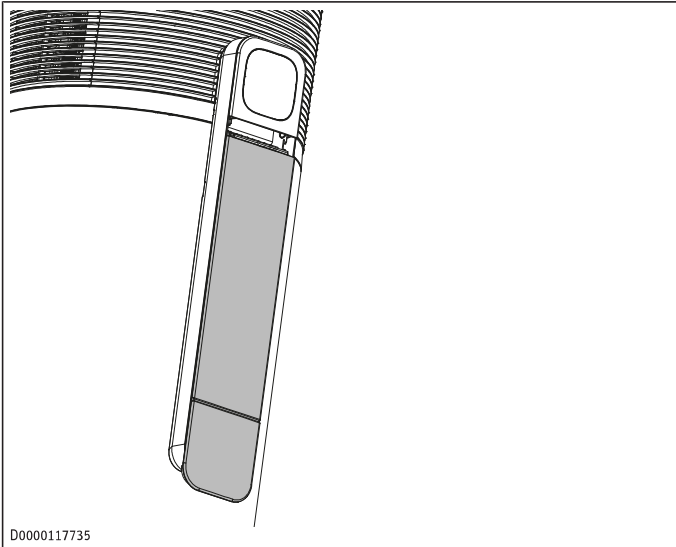

- ▶ Remove the insulation from the emergency/auxiliary heater.

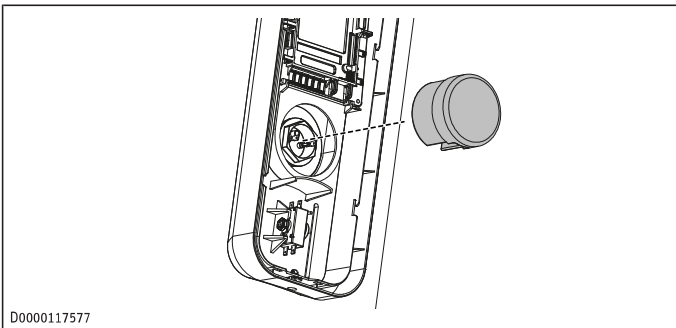

- ▶ Disconnect the electrical connection to the emergency/auxiliary heater.
- ▶ Remove the sensor bulb of the high limit safety cut-out from the sensor pocket.
- ▶ Unscrew the emergency/auxiliary heater from the cylinder connection piece.

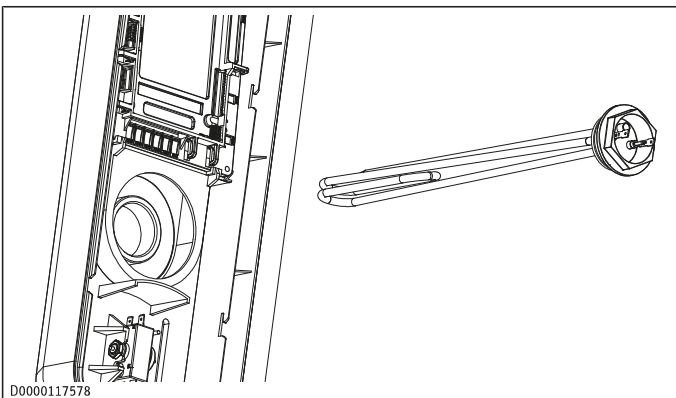

- ▶ Descale the heating element with a brush.
- ▶ Screw the emergency/auxiliary heater into the tank connection piece with the notch pointing upwards.
- ▶ Refill the DHW cylinder (see chapter *Filling the DHW cylinder* [▶ 10]).
- ▶ Check the leak-tightness of the electric emergency/auxiliary heater.
- ▶ Push the sensor bulb of the high limit safety cut-out into the sensor pocket.
- ▶ Re-establish the electrical connection of the emergency/auxiliary heater.

- ▶ Fit the insulation on the emergency/auxiliary heater.
- ▶ Replace the control panel cover.
- ▶ Lock the control panel.
- ▶ Reconnect the appliance to the power supply.

## 15.2 Checking valves

- ▶ Regularly check the valves in the system to ensure the operational reliability of the appliance. The amount of limescale deposits depends on the local water quality.

The following valves should be included in the check:

- Temperature and pressure relief valve
- Pressure reducing valve
- Cold water expansion valve
- ▶ Check that the valves are not scaled up or damaged.
- ▶ Remove any limescale deposits.
- ▶ Replace any faulty valves. Use valves recommended by STIEBEL ELTRON.
- ▶ Check the function of the valves.

## 15.3 Checking consumption indicator on signal anode

- ▶ Isolate the appliance from the power supply.

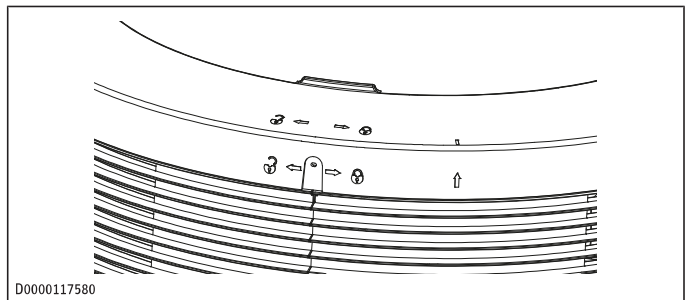

- ▶ Undo the screw at the back of the casing cover.
- ▶ To do this, turn the casing cover clockwise.
- ▶ Remove the casing cover.
- ▶ Remove the front insulation.

### Removing the side casing (only if the ceiling height is insufficient)

If the ceiling height does not provide sufficient working space, carry out the steps in this chapter. Otherwise, continue with the steps in the following chapter.

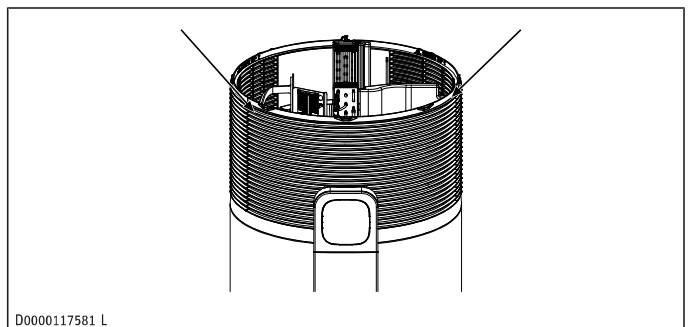

- ▶ Undo the screws on the side casing.
- ▶ Lift up and remove the front side casing from the guide rail.

**Checking consumption indicator on signal anode**

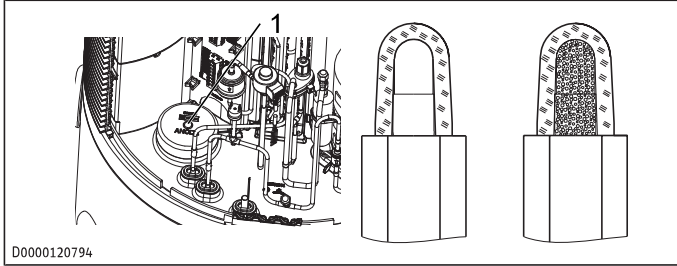

D0000120794

1 Signal anode

Consumption indicator colour	Meaning
white	Signal anode OK
Red	Signal anode depleted, replacement necessary

- ▶ Check the consumption indicator of the signal anode.
- ▶ Replace the signal anode if it is depleted. For this, ensure there is a good connection between the signal anode and the DHW cylinder (maximum transition resistance 0.3 Ω).

**Installing the side casing**

- ▶ Insert the front side casing in the guide rail.

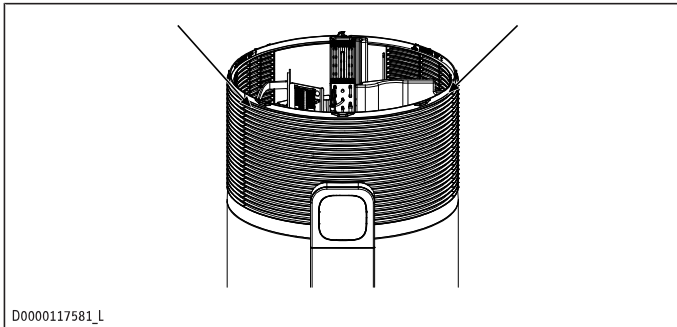

D0000117581\_L

- ▶ Screw the side casing tight.
- ▶ Fit the front insulation.
- ▶ Place the casing cover on the appliance.
- ▶ Turn the casing cover anti-clockwise so that it latches in place.

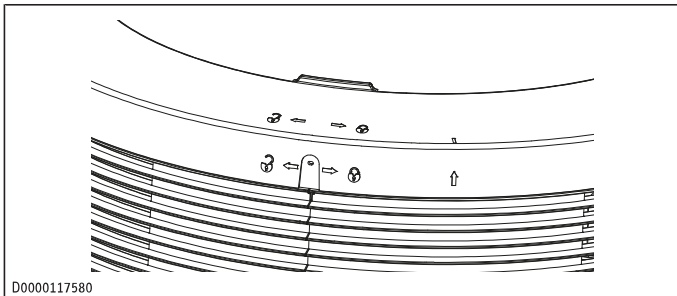

D0000117580

- ▶ Tighten the screw at the back of the casing cover.

**15.4 Replacing the power cable**

The power cable should only be replaced by a qualified contractor.

- ▶ Replace a faulty power cable with a new one.

**16 Shutdown (qualified contractors)**

It is only possible to switch off the appliance by interrupting the power supply.

- ▶ Isolate the appliance from the power supply.

**16.1 Draining the DHW cylinder**

- ▶ Isolate the appliance from the power supply.
- ▶ Close the shut-off valve in the cold water inlet (c01).
- ▶ If there is no drain nearby, route a hose from the cold water inlet to the drain.
- ▶ **WARNING: There is a risk of scalding at outlet temperatures in excess of 43 °C.** Ensure you do not come into direct contact with the outflowing water or components that have heated up.
- ▶ Disconnect the cold water supply line at the cold water inlet.
- ▶ To vent the heat pump, disconnect the DHW line connected to the DHW outlet (c06).

Some residual water will remain in the lower section of the DHW cylinder.

**17 Maintenance and inspection (qualified contractors)**

The area around the unit should be dry, clean and well ventilated. Clean the heating exchanger regularly to maintain good heat exchange and conserve energy.

The operation pressure of the refrigerant system should only be serviced by a certified technician.

You should discharge the water at the bottom of water tank (inlet nozzle cold water) if the unit will not be used for an extended period of time.

You should check the unit thoroughly and fill the system with water fully before using it for the first time after a prolonged period of no usage.

**Checks to the area**

Prior to beginning work on systems containing flammable refrigerants, safety checks are necessary to ensure that the risk of ignition is minimised. For repair to the refrigerating system, the following precautions shall be complied with prior to conducting work on the system.

**Work procedure**

Work shall be undertaken under a controlled procedure so as to minimise the risk of a flammable gas or vapour being present while the work is being performed.

**General work area**

All maintenance staff and others working in the local area shall be instructed on the nature of work being carried out. Work in confined spaces shall be avoided. The area around the workspace shall be sectioned off. Ensure that the conditions within the area have been made safe by control of flammable material.

**Checking for presence of refrigerant**

The area shall be checked with an appropriate refrigerant detector prior to and during work, to ensure the technician is aware of potentially flammable atmospheres. Ensure that the

leak detection equipment being used is suitable for use with flammable refrigerants, i.e. non-sparking, adequately sealed or intrinsically safe.

## Presence of fire extinguisher

If any hot work is to be conducted on the refrigeration equipment or any associated parts, appropriate fire extinguishing equipment shall be available to hand. Have a dry powder or CO<sub>2</sub> fire extinguisher adjacent to the charging area.

## No ignition sources

No person carrying out work in relation to a refrigeration system which involves exposing any pipe work that contains or has contained flammable refrigerant shall use any sources of ignition in such a manner that it may lead to the risk of fire or explosion. All possible ignition sources, including cigarette smoking, should be kept sufficiently far away from the site of installation, repairing, removing and disposal, during which flammable refrigerant can possibly be released to the surrounding space. Prior to work taking place, the area around the equipment is to be surveyed to make sure that there are no flammable hazards or ignition risks. No Smoking signs shall be displayed.

## Ventilated area

Ensure that the area is in the open or that it is adequately ventilated before breaking into the system or conducting any hot work. A degree of ventilation shall continue during the period that the work is carried out. The ventilation should safely disperse any released refrigerant and preferably expel it externally into the atmosphere.

## Checks to the area

Prior to beginning work on systems containing flammable refrigerants, safety checks are necessary to ensure that the risk of ignition is minimised. For repair to the hot-water system, the following precautions shall be complied with prior to conducting work on the system.

## Checks to the refrigeration equipment

Where electrical components are being changed, they shall be fit for the purpose and to the correct specification. At all times STIEBEL ELTRON maintenance and service guidelines shall be followed. If in doubt consult the STIEBEL ELTRON technical department for assistance. The following checks shall be applied to installations using flammable refrigerants:

- The charge size is in accordance with the room size within which the refrigerant containing parts are installed;
- Marking to the equipment continues to be visible and legible. Markings and signs that are illegible shall be corrected.

## Checks to electrical devices

Repair and maintenance to electrical components shall include initial safety checks and component inspection procedures. If a fault exists that could compromise safety, then no electrical supply shall be connected to the circuit until it is satisfactorily dealt with. If the fault cannot be corrected immediately but it is necessary to continue operation, an adequate temporary solution shall be used. This shall be reported to the owner of the equipment so all parties are advised.

Initial safety checks shall include:

- That capacitors are discharged: this shall be done in a safe manner to avoid possibility of sparking;
- That there no live electrical components and wiring are exposed while charging, recovering or purging the system;

- That there is continuity of earth bonding.

## Repairs to sealed components

Sealed electrical components should not be repaired. In the event of a fault, these components must be replaced with original spare parts from STIEBEL ELTRON.

## Repair to intrinsically safe components

Do not apply any permanent inductive or capacitance loads to the circuit without ensuring that this will not exceed the permissible voltage and current permitted for the equipment in use.

Intrinsically safe components are the only types that can be worked on while live in the presence of a flammable atmosphere. The test apparatus shall be at the correct rating.

Replace components only with parts specified by STIEBEL ELTRON. Other parts may result in the ignition of refrigerant in the atmosphere from a leak.

## Cablling

Check that cabling will not be subject to wear, corrosion, excessive pressure, vibration, sharp edges or any other adverse environmental effects. The check shall also take into account the effects of aging or continual vibration from sources such as compressors or fans.

## Detection of flammable refrigerants

Under no circumstances shall potential sources of ignition be used in the searching for or detection of refrigerant leaks. A halide torch (or any other detector using a naked flame) shall not be used.

## Leak detection methods

The following leak detection methods are deemed acceptable for systems containing flammable refrigerants.

Electronic leak detectors shall be used to detect flammable refrigerants, but the sensitivity may not be adequate, or may need re-calibration. (Detection equipment shall be calibrated in a refrigerant-free area.) Ensure that the detector is not a potential source of ignition and is suitable for the refrigerant used. Leak detection equipment shall be set at a percentage of the LFL of the refrigerant and shall be calibrated to the refrigerant employed and the appropriate percentage of gas (25 % maximum) is confirmed.

Leak detection fluids are suitable for use with most refrigerants but the use of detergents containing chlorine shall be avoided as the chlorine may react with the refrigerant and corrode the copper pipe-work.

If a leak is suspected, all naked flames shall be removed/ extinguished.

If a leakage of refrigerant is found which requires brazing, all of the refrigerant shall be recovered from the system, or isolated (by means of shut off valves) in a part of the system remote from the leak. Oxygen free nitrogen (OFN) shall then be purged through the system both before and during the brazing process.

## Removal and evacuation

When breaking into the refrigerant circuit to make repairs or for any other purpose conventional procedures shall be used. However, it is important that best practice is followed since flammability is a consideration. The following procedure shall be adhered to:

- Remove refrigerant;
- Purge the circuit with inert gas;
- Evacuate;

- Purge again with inert gas;
- Open the circuit by cutting or brazing.

The refrigerant charge shall be recovered into the correct recovery cylinders. The system shall be "flushed" with OFN to render the unit safe. This process may need to be repeated several times. Compressed air or oxygen shall not be used for this task. Flushing shall be achieved by breaking the vacuum in the system with OFN and continuing to fill until the working pressure is achieved, then venting to atmosphere, and finally pulling down to a vacuum. This process shall be repeated until no refrigerant is within the system.

When the final OFN charge is used, the system shall be vented down to atmospheric pressure to enable work to take place. This operation is absolutely vital if brazing operations on the pipework are to take place.

Ensure that the outlet of the vacuum pump is not close to any potential ignition sources and that ventilation is available.

## Labelling

Equipment shall be labelled stating that it has been decommissioned and emptied of refrigerant. The label shall be dated and signed. Ensure that there are labels on the equipment stating the equipment contains flammable refrigerant.

## Recovery

When removing refrigerant from a system, either for servicing or decommissioning, it is recommended good practice that all refrigerants are removed safely.

When transferring refrigerant into cylinders, ensure that only appropriate refrigerant recovery cylinders are employed. Ensure that the correct number of cylinders for holding the total system charge is available. All cylinders to be used are designated for the recovered refrigerant and labelled for that refrigerant (i.e. special cylinders for the recovery of refrigerant). Cylinders shall be complete with pressure relief valve and associated shutoff valves in good working order. Empty recovery cylinders are evacuated and, if possible, cooled before recovery occurs.

The recovery equipment shall be in good working order with a set of instructions concerning the equipment that is at hand and shall be suitable for the recovery of flammable refrigerants. In addition, a set of calibrated weighing scales shall be available and in good working order. Hoses shall be complete with leak-free disconnect couplings and in good condition. Before using the recovery machine, check that it is in satisfactory working order, has been properly maintained and that any associated electrical components are sealed to prevent ignition in the event of a refrigerant release. Consult manufacturer if in doubt.

The recovered refrigerant shall be returned to the refrigerant supplier in the correct recovery cylinder, and the relevant Waste Transfer Note arranged. Do not mix refrigerants in recovery units and especially not in cylinders.

If the compressor or compressor oil are to be removed, ensure that they have been evacuated to an acceptable level to make certain that flammable refrigerant does not remain within the lubricant. The evacuation process shall be carried out prior to returning the compressor to the suppliers. Only electric heating to the compressor body shall be employed to accelerate this process. When oil is drained from a system, it shall be carried out safely.

## Decommissioning

Before carrying out this procedure, it is essential that the technician is completely familiar with the equipment and all its detail. It is recommended good practice that all refrigerants are

recovered safely. Prior to the task being carried out, an oil and refrigerant sample shall be taken in case analysis is required prior to re-use of reclaimed refrigerant. It is essential that electrical power is available before the task is commenced.

- ▶ Become familiar with the equipment and its operation.
- ▶ Isolate system electrically.
- ▶ Before attempting the procedure ensure that:
  - Mechanical handling equipment is available, if required, for handling refrigerant cylinders;
  - All personal protective equipment is available and being used correctly;
  - The recovery process is supervised at all times by a competent person;
  - Recovery equipment and cylinders conform to the appropriate standards.
- ▶ Pump down refrigerant system, if possible.
- ▶ If a vacuum is not possible, make a manifold so that refrigerant can be removed from various parts of the system.
- ▶ Make sure that cylinder is situated on the scales before recovery takes place.
- ▶ Start the recovery machine and operate in accordance with manufacturer's instructions.
- ▶ Do not overfill cylinders. (No more than 80 % volume liquid charge).
- ▶ Do not exceed the maximum working pressure of the cylinder, even temporarily.
- ▶ When the cylinders have been filled correctly and the process completed, make sure that the cylinders and the equipment are removed from site promptly and all isolation valves on the equipment are closed off.

Recovered refrigerant shall not be charged into another refrigeration system unless it has been cleaned and checked.

## Charging procedures

In addition to conventional charging procedures, the following requirements shall be followed.

- Ensure that contamination of different refrigerants does not occur when using charging equipment. Hoses or lines shall be as short as possible to minimise the amount of refrigerant contained in them.
- Cylinders shall be kept upright.
- Ensure that the refrigeration system is earthed prior to charging the system with refrigerant.
- Label the system when charging is complete (if not already).
- Extreme care shall be taken not to overfill the refrigeration system.
- Prior to recharging the system it shall be pressure tested with OFN. The system shall be leak tested on completion of charging but prior to commissioning. A follow up leak test shall be carried out prior to leaving the site.

## 18 Specification

### 18.1 Dimensions and connections

#### 18.1.1 SHP-O 200 Plus

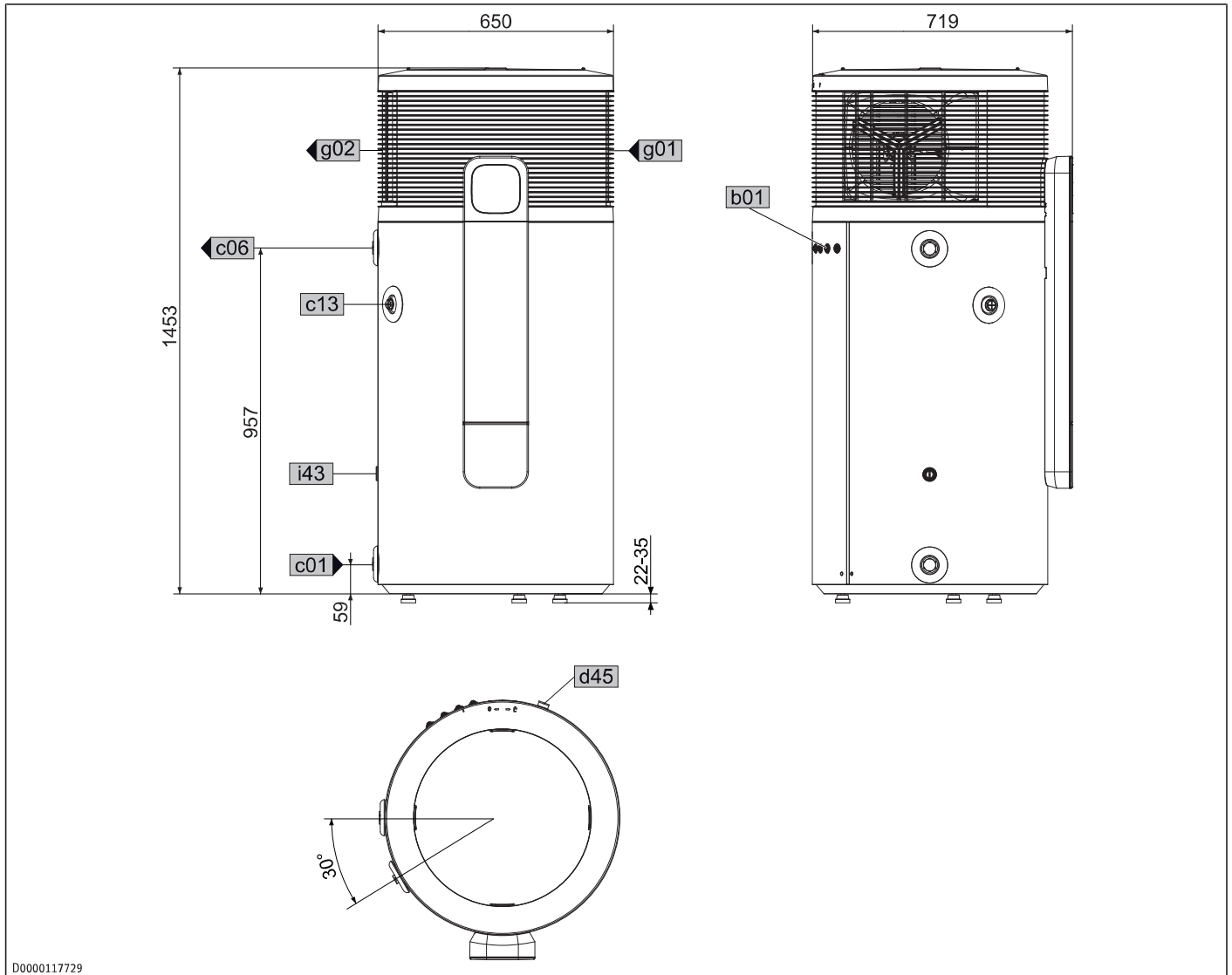

D0000117729

b01	Entry electrical cables		
c01	Cold water inlet	Male thread	G 1
c06	DHW outlet	Male thread	G 1
c13	T&P valve	Female thread	Rp 1/2
d45	Condensate drain	Male thread	G 3/4
g01	Air intake		
g02	Air discharge		
i43	Cover for manufacturing aperture		

18.1.2 SHP-O 300 Plus

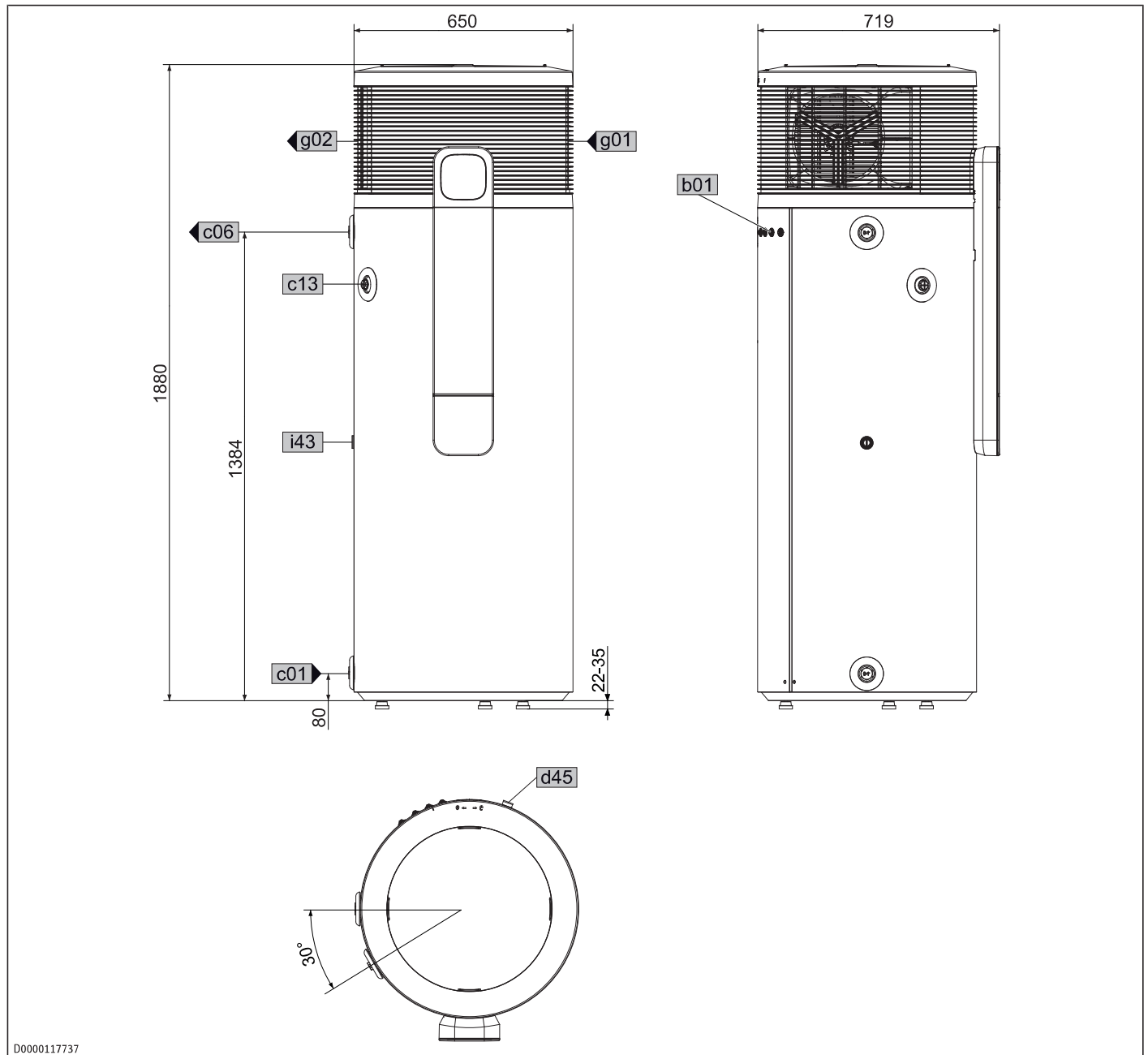

D0000117737

b01	Entry electrical cables		
c01	Cold water inlet	Male thread	G 1
c06	DHW outlet	Male thread	G 1
c13	T&P valve	Female thread	Rp 1/2
d45	Condensate drain	Male thread	G 3/4
g01	Air intake		
g02	Air discharge		
i43	Cover for manufacturing aperture		

## 18.2 Wiring diagram

AA02	Integral control unit 1 EB R.WWP
AA06	Programming unit
AA09	Wireless module
BP03	Pressure sensor, low pressure (16 bar)
BP05	Pressure switch, high pressure (31 bar)
BT21/22	Temperature sensor, cylinder top/integral
BT31	Temperature sensor, air intake
BT40	Temperature sensor, hot gas
BT45	Temperature sensor, evaporator discharge
BT55	Temperature limiter, high limit safety cut-out for emergency and auxiliary heater
BT58	Temperature sensor, fin array, evaporator
CA01	Run capacitor, compressor
EB08	Emergency and auxiliary heater
FA01	Internal motor overload relay

FC11	Fuse 1.25 A
FH800	Retainer for fuse
MA01	Compressor motor
MA04	Motor, expansion valve
MA20	Motor, heat pump fan
S200	DIP switch
XD14	SG Ready terminal
XD20	Main connection terminal, internal
XD21	L block terminal
XD22	N block terminal
XD34	Sensor terminal
XD35	Control terminal
XD36	Actuator terminal
XD37	Adaptor terminal
XE17	Earth terminal, cylinder, internal
XE19	Earth stud, terminal plate
XE20	Earth stud, casing

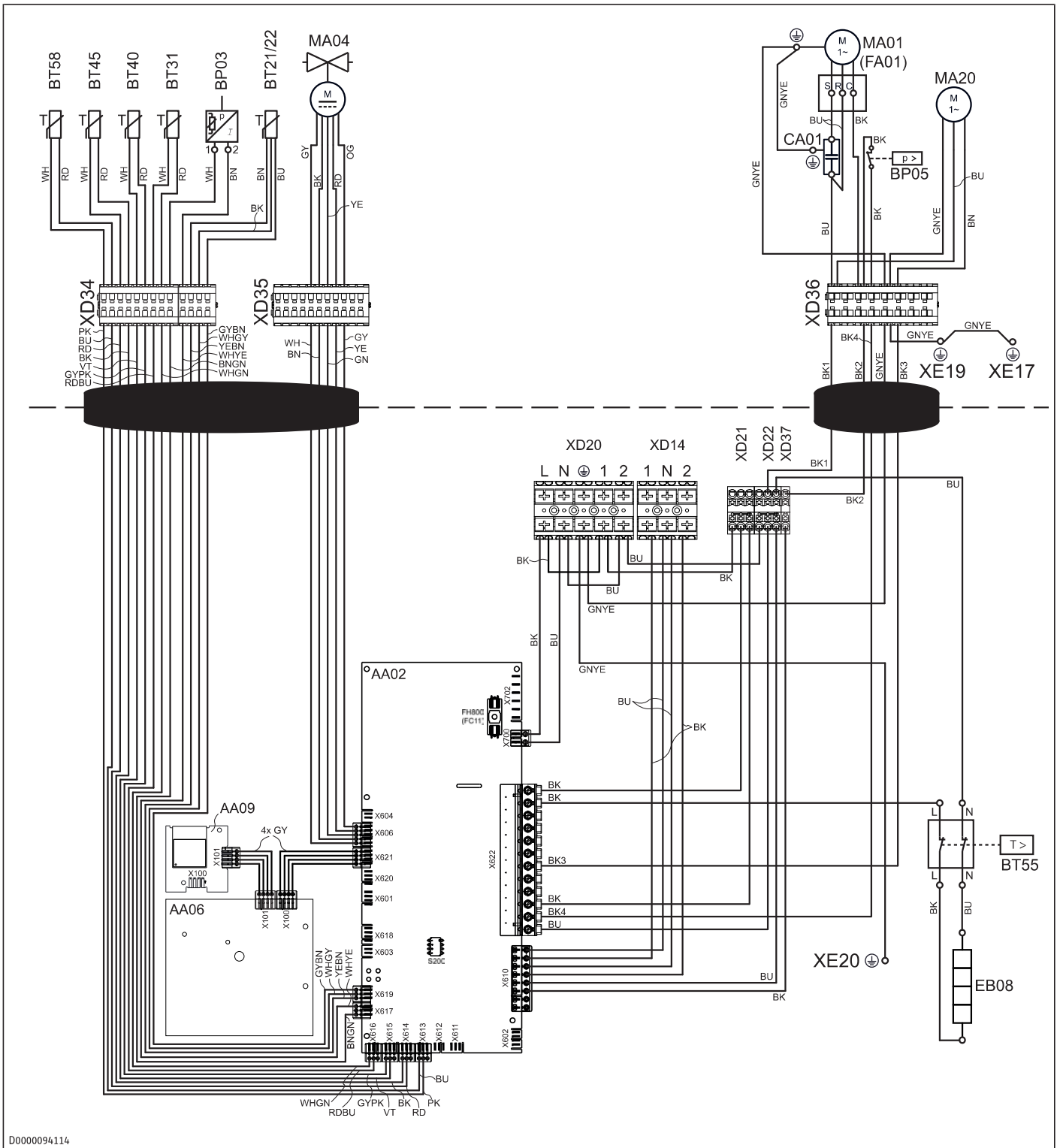

D0000094114

## 18.3 Data table

		SHP-O 200 Plus 204472	SHP-O 300 Plus 204473
<b>Hydraulic data</b>			
Nominal capacity	l	200	300
<b>Application limits</b>			
Max. DHW temperature with heat pump	°C	65	65
Max. DHW temperature with emergency/auxiliary heater	°C	65	65
Max. permissible DHW temperature in the cylinder	°C	70	70
High limit safety cut-out	°C	89	89
Min./max. application limits, heat source for heat pump operation	°C	+6/+43	+6/+43
Min./max. application limits, ambient temperature, cylinder	°C	-5/+50	-5/+50
Min. installation room volume (recirculation air mode, general domestic use)	m <sup>3</sup>	13	13
Max. permissible operating pressure, cold water/DHW	MPa	0.85	0.85
Permissible operating pressure, refrigerant circuit	MPa	3.1	3.1
Min./max. conductivity, DHW	µS/cm	100-1500	100-1500
<b>Power consumption</b>			
Power consumption, emergency/auxiliary heater (230 V)	kW	1.50	1.50
Average power consumption, heat pump (230 V) (A19/W15-61 I AS/NZS 5125.1)	kW	0.45	0.44
Max. power consumption, heat pump (230 V)	kW	0.7	0.7
<b>Electrical data</b>			
Power supply		1/N/PE 220-240 V ~ 50 Hz	1/N/PE 220-240 V ~ 50 Hz
Permissible voltage range, external signal transmitter		~ 220-240 V 50/60 Hz	~ 220-240 V 50/60 Hz
Max. operating current	A	9.88	9.88
Max. starting current	A	19.08	19.08
Fuse protection min.*	A	C10	C10
Rated voltage	V	220-240	220-240
Rated current	A	2.25	2.25
Max. power consumption, heat pump + emergency/auxiliary heater	kW	2.125	2.125
<b>Sound emissions</b>			
Sound power level LWA, EN12012	dB(A)	58,2	58,2
Average sound pressure level at 1 m distance, free field	dB(A)	53	53
<b>Versions</b>			
IP rating		IP24	IP24
Refrigerant		R290	R290
Refrigerant charge	kg	0.152	0.152
Global warming potential of the refrigerant (GWP100)		0.02	0.02
CO <sub>2</sub> equivalent (CO <sub>2</sub> e)	t	0.000456	0.000456
Power cable length approx.	mm	2000	2000
Default temperature setting	°C	61	61
<b>Dimensions</b>			
Height	mm	1478	1903
Diameter	mm	650	650
Height when tilted, incl. packaging	mm	1798	2197

		SHP-0 200 Plus	SHP-0 300 Plus
<b>Weights</b>			
Weight, empty	kg	98	117
Weight, full	kg	304	422
<b>Connections</b>			
Condensate connection		G 3/4 A	G 3/4 A
Water connection		G 1 A	G 1 A
Safety valve connection		Rp 1/2	Rp 1/2
<b>Values</b>			
Type of anode		Signal anode	Signal anode
Air flow rate	m <sup>3</sup> /h	460	460
<b>Further details</b>			
Maximum height for installation	m	<2000	<2000

\* Fuse protection max. C16

# WARRANTY

## Warranty Stiebel Eltron Australia Only - According to national regulations in Australia

Stiebel Eltron Warranty for Heat Pumps

### Who gives the warranty

- The warranty is given by Stiebel Eltron (Aust) Pty Ltd (A.B.N. 82 066 271 083) of 294 Salmon Street, Port Melbourne, Victoria, 3207 ("we", "us" or "our").

### The warranty

- This warranty applies to Stiebel Eltron Heat pumps (the "unit").
- Subject to the warranty exclusions we will repair or replace, at our absolute discretion, a faulty component in your unit free of charge if it fails to operate in accordance with its specifications, and you make a valid warranty claim in accordance with this warranty, during the warranty period.
- If we repair or replace a faulty component to your unit under this warranty, the warranty period is not extended from the time of the repair or replacement. The repaired part will be warranted for an additional 12 months from installation or for the remaining duration of original warranty.
- The warranty period commences on the date of completion of the installation of the unit. Where the date of completion of installation is not known, then the warranty period will commence 2 months after the date of manufacture.
- The warranty period for a unit used for domestic purposes is shown in the table below. Domestic purposes means that the unit is used in a domestic dwelling.

Component	Warranty period
Cylinder and condenser	7 years
Sealed refrigeration system including compressor, evaporator, valves and associated pipe work. All other electrical componentry.	5 years
T&P relief valve	1 year

- The warranty period for a unit used for commercial purposes is shown in the table below. Commercial purposes means that the unit is used for a non-domestic purpose and includes but is not limited to being used in a motel, hotel, mining camp or nursing home.

Component	Warranty period
Cylinder and condenser	2 years
Sealed refrigeration system including compressor, evaporator, valves and associated pipe work. All other electrical componentry.	2 years
T&P relief valve	1 year

### Your entitlement to make a warranty claim

- You are entitled to make a warranty claim if:
  - you own the unit or if you have the owner's consent to represent the owner of the unit;
  - you contact us within a reasonable time of discovering the problem with the unit and in any event within 30 days.

### How you make a warranty claim

- To make a warranty claim you must provide us with the following information:
  - The model number of the unit;
  - A description of the problem with the unit;
  - The name, address and contact details (such as phone number and e-mail address) of the owner;
  - The address where the unit is installed and the location (e.g. at side of house);
  - The serial number of the unit;
  - The date of purchase of the unit and the name of the seller of the unit;
  - The date of installation of the unit;
  - A copy of the certificate of compliance when the unit was installed.
  - The contact details for you to make your warranty claim are:
 

Name: Stiebel Eltron (Aust) Pty Ltd  
Address: 294 Salmon Street, Port Melbourne, Victoria, 3207  
Telephone: 1800 153 351  
(8.00 am to 5.00 pm AEST Monday to Friday)
  - Contact person: Customer Service Representative  
E-mail: service@stiebel-eltron.com.au

- We will arrange a suitable time with you to inspect and test the unit.

### Warranty exclusions

- We may reject your warranty claim if:
  - The unit was not installed by registered and qualified plumber.
  - The unit was not installed and commissioned:
    - in Australia;
    - in accordance with the Operating and Installation Guide; and
    - in accordance with the relevant statutory and local requirements of the State or Territory in which the unit is installed.
  - The unit has not been operated or maintained in accordance with the Operating and Installation Guide.
  - The unit does not bear its original Serial Number for Rating Label.
  - The unit was damaged by any or any combination of the following:
    - normal fair wear and tear;
    - connection to an incorrect water supply;
    - connection to water from a bore, dam or swimming pool;
    - connection to an incorrect or faulty power supply;
    - connection to faulty equipment, such as damaged valves;
    - foreign matter in the water supply, such as sludge or sediment;
    - corrosive elements in the water supply;
    - accidental or malicious damage;
    - act of God, including damage by flood, storm, fire, lightning strike, cyclones, earthquakes, natural disasters or other similar actions of the elements;
    - excessive water pressure, negative water pressure (partial vacuum) or water pressure pulsation;
    - ingress of vermin.
  - The unit was damaged before it was installed e.g. it was damaged in transit.
  - An unauthorised person has modified, serviced, repaired or attempted to repair the unit without our consent.
  - Non genuine parts other than those manufactured or approved by us have been used on the unit.
- We may charge you:
  - for any additional transport costs if the unit is installed more than 30 kilometres from our closest authorised service technician.
  - for the extra time it takes our authorised service technician to access the unit for inspection and testing if it is not sited in accordance with the Operating and Installation Guide and not readily accessible for inspection.
  - for any extra costs of our authorised service technician to make the unit safe for inspection.
- You must ensure that access to the unit by our authorised service technician is safe and free from obstruction.
- Our authorised service technician may refuse to inspect and test the unit until you provide safe and free access to it, at your cost.
- If we reject your warranty claim in accordance with clause 12, we may charge you for our authorised service technician's labour costs to inspect and test the unit.
- In order to properly test the unit we may remove it to another location for testing.

### Australian Consumer Law

- Our goods come with guarantees that cannot be excluded under the Australian Consumer Law. You are entitled to a replacement or refund for a major failure and compensation for any other reasonably foreseeable loss or damage. You are also entitled to have the goods repaired or replaced if the goods fail to be of acceptable quality and the failure does not amount to a major failure.
- The Stiebel Eltron warranty for the unit is in addition to any rights and remedies you may have under the Australian Consumer Law.

**STIEBEL ELTRON GmbH & Co. KG**

Dr.-Stiebel-Straße 33 | 37603 Holzminden | Germany  
info@stiebel-eltron.com | www.stiebel-eltron.com



A 365774-47287-0042  
B 366674-46923-9974