

OPERATION AND INSTALLATION

Electronically controlled comfort instantaneous water heater

- » DHB-E 13 LCD AU
- » DHB-E 18 LCD AU
- » DHB-E 27 LCD AU

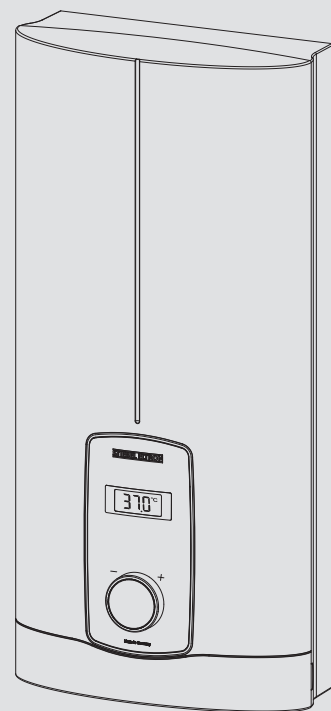

STIEBEL ELTRON

SPECIAL INFORMATION

OPERATION

1. General information	3
1.1 Safety instructions	3
1.2 Other symbols in this documentation	3
1.3 Units of measurement	3
2. Safety	3
2.1 Intended use	3
2.2 General safety instructions	4
2.3 Test symbols	4
3. Appliance description	4
4. Settings and displays	4
4.1 Selecting the set temperature	4
4.2 Recommended settings	5
5. Cleaning, care and maintenance	5
6. Troubleshooting	5

INSTALLATION

7. Safety	6
7.1 General safety instructions	6
7.2 Shower operation	6
7.3 Instructions, standards and regulations	6
8. Appliance description	6
8.1 Standard delivery	6
8.2 Accessories	6
9. Preparation	6
9.1 Installation location	6
9.2 Minimum clearances	7
9.3 Water installation	7
10. Installation	7
10.1 Standard installation	7
11. Commissioning	10
11.1 Preparation	10
11.2 Initial start-up	10
11.3 Recommissioning	11
12. Appliance shutdown	11
13. Alternative installation methods	11
13.1 Electrical connection from above on unfinished walls	12
13.2 Electrical connection on unfinished walls with short power cable	12
13.3 Electrical connection on finished walls	12
13.4 Water installation on unfinished walls	13
13.5 Wall mounting bracket when replacing appliance	13
13.6 Installation with offset tiles	13
13.7 Pivoting appliance cover	14
13.8 Operation with preheated water	14
13.9 Horizontal installation of the appliance	14
14. Service information	15
15. Troubleshooting	15
16. Maintenance	16
17. Specification	16
17.1 Dimensions and connections	16
17.2 Wiring diagram	17

17.3 Domestic hot water output	17
17.4 Application areas / Conversion table	17
17.5 Pressure drop	17
17.6 Fault conditions	17
17.7 Data table	18

SOFTWARE COPYRIGHT

ENVIRONMENT AND RECYCLING

WARRANTY

SPECIAL INFORMATION

- The appliance may be used by children aged 3 and older and persons with reduced physical, sensory or mental capabilities or a lack of experience and know-how, provided that they are supervised or they have been instructed on how to use the appliance safely and have understood the potential risks. Children must never play with the appliance. Cleaning and maintenance by the user may not be carried out by children unless they are supervised.
- If using preheated water, the tap can reach a temperature of up to 70 °C during operation. There is a risk of scalding at outlet temperatures in excess of 43 °C.
- The appliance is suitable for supplying a shower (shower operation). If the appliance is also or exclusively used for shower operation, the qualified contractor must adjust the temperature setting range to 43 °C using the internal anti-scalding protection on the appliance. When using preheated water, ensure that the inlet temperature does not exceed 55 °C.
- In Australia, the use of a temperature controller is required to meet the requirements of AS 3498 when showers, bathtubs or washbasins are supplied with water. The maximum temperature of 50 °C must not be exceeded.

OPERATION

General information

- Ensure the appliance can be separated from the power supply by an isolator that disconnects all poles with at least 3 mm contact separation.
- The specified voltage must match the power supply.
- The appliance must be connected to the earth conductor.
- The appliance must be permanently connected to fixed wiring.
- Secure the appliance as described in chapter "Installation / Installation".
- Observe the maximum permissible pressure (see chapter "Installation / Specification / Data table").
- The specific water resistivity of the mains water supply must not be undershot (see chapter "Installation / Specification / Data table").
- Drain the appliance as described in chapter "Installation / Maintenance / Draining the appliance".

OPERATION

1. General information

The chapters "Special information" and "Operation" are intended for both users and qualified contractors.

The chapter "Installation" is intended for qualified contractors.



Note

Read these instructions carefully before using the appliance and retain them for future reference. Pass on the instructions to a new user if required.

1.1 Safety instructions

1.1.1 Structure of safety instructions



KEYWORD Type of risk

Here, possible consequences are listed that may result from failure to observe the safety instructions.

► Steps to prevent the risk are listed.

1.1.2 Symbols, type of risk

Symbol	Type of risk
	Injury
	Electrocution
	Burns (burns, scalding)

1.1.3 Keywords

KEYWORD	Meaning
DANGER	Failure to observe this information will result in serious injury or death.
WARNING	Failure to observe this information may result in serious injury or death.
CAUTION	Failure to observe this information may result in non-serious or minor injury.

1.2 Other symbols in this documentation



Note

General information is identified by the adjacent symbol. ► Read these texts carefully.

Symbol	Meaning
	Material losses (appliance damage, consequential losses and environmental pollution)
	Appliance disposal

► This symbol indicates that you have to do something. The action you need to take is described step by step.

1.3 Units of measurement



Note

All measurements are given in mm unless stated otherwise.

2. Safety

2.1 Intended use

This appliance is suitable for heating domestic hot water or for reheating preheated water. The appliance can supply one or more draw-off points.

Water will not be reheated if the maximum inlet temperature for reheating is exceeded.

The appliance is intended for domestic use. It can be used safely by untrained persons. The appliance can also be used in non-domestic environments, e.g. in small businesses, as long as it is used in the same way.

Appliance description

Any other use beyond that described shall be deemed inappropriate. Observation of these instructions and of the instructions for any accessories used is also part of the correct use of this appliance.

2.2 General safety instructions



CAUTION Burns
If using preheated water, the tap can reach a temperature of up to 70 °C during operation. There is a risk of scalding at outlet temperatures in excess of 43 °C.



CAUTION Burns
If operating with preheated water, e.g. from a solar thermal system, the DHW temperature may vary from the selected set temperature.



CAUTION Burns
If children or persons with limited physical, sensory or mental capabilities use the appliance, a permanent and unchangeable temperature limit is necessary. Ask a qualified contractor to set the internal anti-scalding protection.



WARNING Injury
The appliance may be used by children aged 3 and older and persons with reduced physical, sensory or mental capabilities or a lack of experience and know-how, provided that they are supervised or they have been instructed on how to use the appliance safely and have understood the potential risks. Children must never play with the appliance. Children must never clean the appliance or perform user maintenance unless they are supervised.



WARNING
For continued safety of this appliance it must be installed, operated and maintained in accordance with the manufacturer's instructions.



WARNING
This appliance may deliver water at high temperature. Refer to the plumbing code of Australia (PCA), local requirements and installation instructions to determine if additional delivery temperature control is required.



Material losses
The user should protect the appliance and its tap against frost.

2.3 Test symbols

See type plate on the appliance

3. Appliance description

The appliance switches on automatically as soon as you open the hot water valve on the tap. When you close the tap, the appliance switches off again automatically.

The appliance heats water as it flows through it. The set temperature is adjustable. Upwards of a certain flow rate, the control unit selects the required heating output, subject to the temperature selected and the cold water temperature.

The electronically controlled instantaneous water heater with automatic output matching maintains a consistent outlet temperature. It is irrespective of the inlet temperature, up to the maximum output of the appliance.

If the appliance is operated with preheated water and the inlet temperature exceeds the set temperature, the water is not heated further.

Heating system

The bare wire heating system is enclosed within a pressure-tested plastic jacket. The heating system with its stainless steel internal indirect coil is suitable for hard and soft water areas and is largely unsusceptible to scale build-up. The heating system ensures rapid and efficient DHW provision.



Note
The appliance is equipped with an air detector that largely prevents damage to the heating system. If, during operation, air is drawn into the appliance, the appliance shuts down for one minute, thereby protecting the heating system.

4. Settings and displays

4.1 Selecting the set temperature

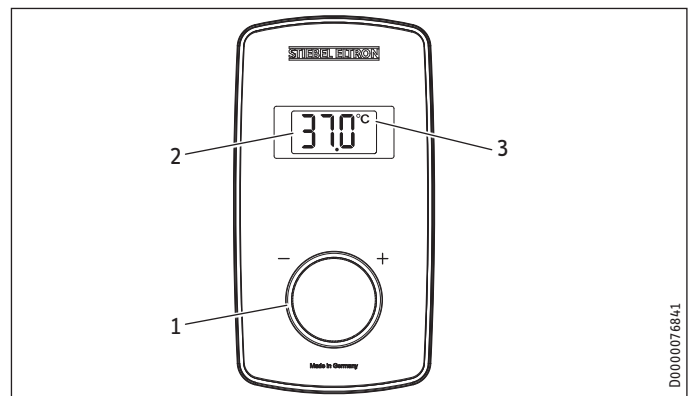

- 1 Temperature selector for adjusting set temperature (no end-stop): "OFF", 20 - 60 °C
- 2 Display
- 3 Temperature unit [°C/°F]

Temperature settings in steps			
Temperature range	Step	Temperature range	Step
20 °C ... 60 °C	1 °C	68 °F ... 140 °F	1 °F

OPERATION

Cleaning, care and maintenance

Selecting the temperature indicator

You can choose to display the temperature in °C or °F, as required.

- ▶ Turn the temperature selector anti-clockwise, past the OFF indicator and another five complete turns, until you find yourself in temperature unit selection mode. Then select the temperature unit using the temperature selector. After 30 seconds, the appliance exits selection mode automatically and the selected temperature unit is retained.



Note

If the outlet temperature is not high enough when the draw-off valve is fully open and the temperature selector is set to maximum, then more water is flowing through the appliance than can be heated by the heating system (appliance working at maximum output).

- ▶ Reduce the water volume until the preferred temperature delivery is achieved.

4.2 Recommended settings

Your instantaneous water heater offers maximum precision and maximum convenience in DHW provision. Should you nonetheless be operating the appliance with a thermostatic valve, we recommend that you:

- ▶ Adjust the set temperature on the appliance to over 50 °C. Then set the required set temperature on the thermostatic valve.

Saving energy

The following recommended settings will result in the lowest energy consumption:

- 38 °C for hand washbasins, showers, bath
- 55 °C for kitchen sinks

Temperature limit via internal anti-scalding protection (qualified contractor)

If required, the qualified contractor can set a permanent temperature limit, for example in nurseries, hospitals etc.

Limiting it in this way prevents water from flowing out of the appliance at temperatures which could cause injury.

Recommended setting for operation with a thermostatic valve and water preheated by solar energy

- ▶ Set the temperature at the instantaneous water heater to the maximum temperature.

Following an interruption to the water supply



Material losses

To ensure that the bare wire heating system is not damaged following an interruption to the water supply, the appliance must be restarted taking the following steps.

- ▶ Disconnect the appliance from the power supply by removing the fuses/tripping the MCBs.
- ▶ Open the tap for one minute until the appliance and its upstream cold water inlet line are free of air.
- ▶ Switch the power back ON.

5. Cleaning, care and maintenance

- ▶ Never use abrasive or corrosive cleaning agents. A damp cloth is sufficient for cleaning the appliance.
- ▶ Check the taps regularly. Limescale deposits at the tap outlets can be removed using commercially available descaling agents.

6. Troubleshooting

Problem	Cause	Remedy
The appliance will not start despite the DHW valve being fully open.	There is no power.	Check the fuses/MCBs in your fuse box/distribution board.
	The aerator in the tap or the shower head is scaled up or soiled.	Clean and/or descale the aerator or shower head.
When hot water is being drawn off, cold water flows for a short period.	The water supply has been interrupted.	Vent the appliance and the cold water inlet line.
	The air detector detects air in the water. It switches off the heating output briefly.	The appliance restarts automatically after 1 minute.
The required temperature cannot be set.	Internal anti-scalding protection is activated.	The internal anti-scalding protection can only be adjusted by the qualified contractor.



Note

Programming unit displays and selected settings are retained following a power failure.

If you cannot remedy the fault, contact your qualified contractor. To facilitate and speed up your request, provide the number from the type plate (000000-0000-000000).

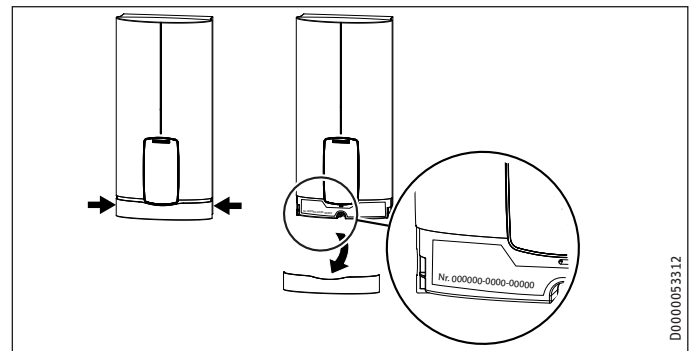

INSTALLATION

7. Safety

Only a qualified contractor should carry out installation, commissioning, maintenance and repair of the appliance.

7.1 General safety instructions

We guarantee trouble-free function and operational reliability only if original accessories and spare parts intended for the appliance are used.



Material losses

Observe the maximum inlet temperature. Higher temperatures may damage the appliance. You can limit the maximum inlet temperature by installing a central thermostatic valve (see chapter "Appliance description / Accessories").



WARNING Electrocutation

This appliance contains capacitors which are discharged when disconnected from the power supply. The capacitor discharge voltage may briefly exceed 60 V DC.

7.2 Shower operation



CAUTION Burns

- The appliance is suitable for supplying a shower (shower operation). If the appliance is also or exclusively used for shower operation, the qualified contractor must adjust the temperature setting range to 43 °C using the internal anti-scalding protection on the appliance. When using preheated water, ensure that the inlet temperature does not exceed 55 °C.
- In Australia, the use of a temperature controller is required to meet the requirements of AS 3498 when showers, bathtubs or washbasins are supplied with water. The maximum temperature of 50 °C must not be exceeded.

7.3 Instructions, standards and regulations



Note

Observe all applicable national and regional regulations and instructions.



Note

The installation of this appliance shall conform to the Plumbing Code of Australia (PCA), and the New Zealand Building Code.

- The IP 24 / IP 25 protection rating can only be ensured with a correctly fitted cable grommet.

- The specific electrical resistance of the water must not fall below that stated on the type plate. In a linked water network, factor in the lowest electrical resistance of the water. Your water supply utility will advise you of the specific electrical water resistance or conductivity.

8. Appliance description

8.1 Standard delivery

The following are delivered with the appliance:

- Wall mounting bracket
- Installation template
- 2 plugs
- 2 extensions
- 2 caps
- 2 tees
- 8 flat gaskets
- Strainer
- Plastic profile washer
- Plastic connection pieces / Installation aid
- Cap and back panel guides
- Jumper for internal anti-scalding protection

8.2 Accessories

Wireless remote control

- FFB 4 Set AP

9. Preparation

9.1 Installation location



Material losses

Install the appliance in a room free from the risk of frost.

- ▶ Always install the appliance vertically and near the draw-off point. For horizontal installation, see chapter "Alternative installation methods / Horizontal installation of the appliance".

The appliance is suitable for undersink and oversink installation.

Undersink installation

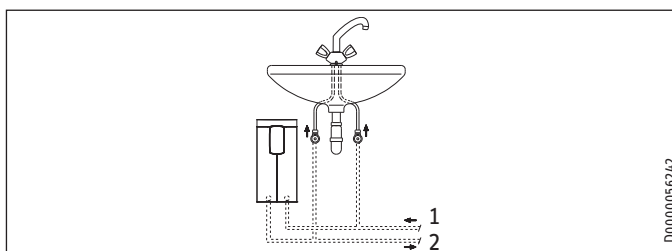

- 1 Cold water inlet
- 2 DHW outlet

INSTALLATION

Installation

Oversink installation

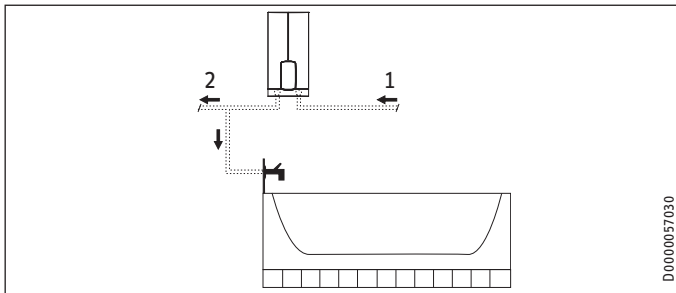

- 1 Cold water inlet
- 2 DHW outlet



Note

- ▶ Mount the appliance on the wall. The wall must have sufficient load bearing capacity.

9.2 Minimum clearances

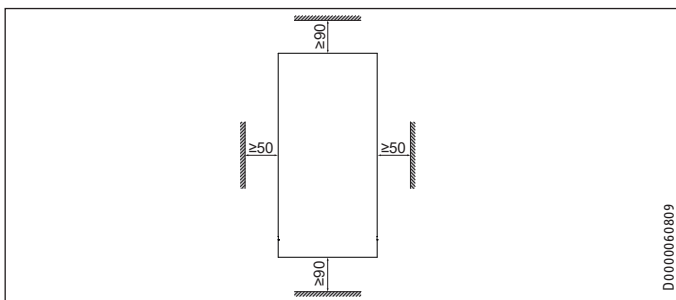

- ▶ Maintain the minimum clearances to ensure trouble-free operation of the appliance and facilitate maintenance work.

9.3 Water installation

- ▶ Flush the water line thoroughly.

Taps/valves

Use appropriate pressure taps. Open vented taps are not permissible.

Permissible water line materials

- Cold water inlet line:
Pipes made from galvanised steel, stainless steel, copper or plastic
- DHW outlet line:
Stainless steel pipe, copper pipe or plastic pipe



Material losses

If plastic pipework systems are used, take into account the maximum inlet temperature and the maximum permissible pressure.

Flow rate

- ▶ Ensure that the flow rate for switching on the appliance is achieved.
- ▶ Increase the water line pressure if the required flow rate is not achieved when the draw-off valve is fully open. If the flow rate is still not achieved, remove the flow limiter (see chapter "Installation / Installation / Removing the flow limiter").

10. Installation

Factory settings	DHB-E 13 LCD AU	DHB-E 18 LCD AU	DHB-E 27 LCD AU
Internal anti-scalding protection	Tmax (= 60 °C)	Tmax (= 60 °C)	Tmax (= 60 °C)

Standard installation	DHB-E 13 LCD AU	DHB-E 18 LCD AU	DHB-E 27 LCD AU
Electrical connection from below on unfinished walls	X	X	X
Water connection, installation on finished walls	X	X	X

For further installation options, see chapter "Alternative installation methods".

10.1 Standard installation

Opening the appliance

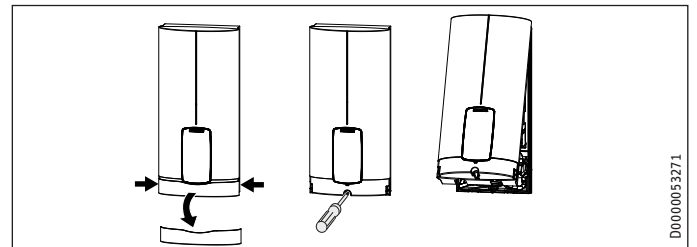

- ▶ Open the appliance by holding the fascia at the side and pulling forwards away from the appliance cover. Undo the screw. Pivot open the appliance cover.

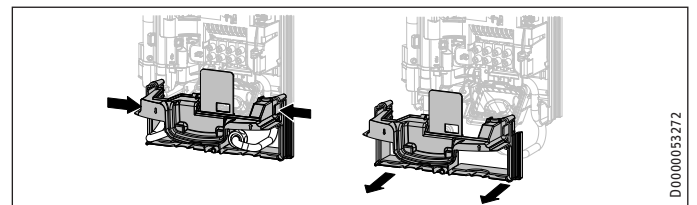

- ▶ Remove the back panel by pressing the two locking tabs and pulling the lower section of the back panel forwards.

INSTALLATION

Installation

Preparing the power cable on unfinished walls, for connection from below

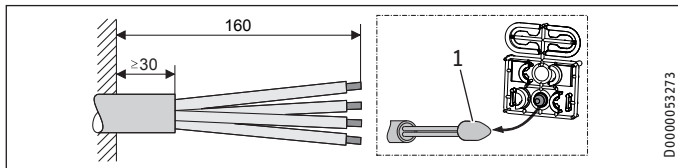

- 1 Cable entry installation aid
- ▶ Prepare the power cable.

Fitting the wall mounting bracket

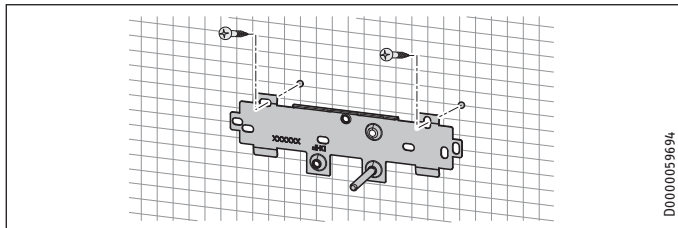

- ▶ Mark out the holes for drilling using the installation template. If the appliance is to be installed on finished walls, also mark out the fixing hole in the lower section of the template.
- ▶ Drill the holes and secure the wall mounting bracket at 2 points using suitable fixing materials (screws and rawl plugs are not part of the standard delivery).
- ▶ Fit the wall mounting bracket.

Preparing the water connection

- !** **Material losses**
Carry out all water connection and installation work in accordance with regulations.

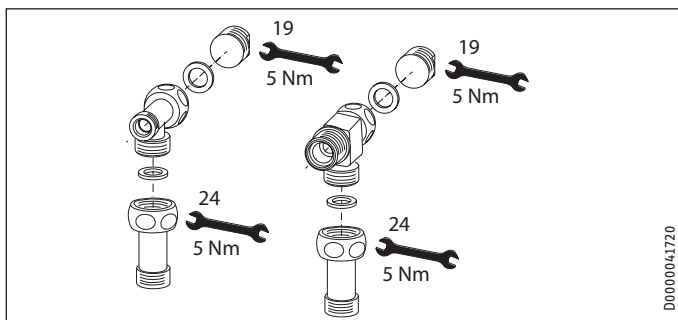

- ▶ Remove the caps from the tees.
- ▶ Fit the plugs and the extensions with gaskets.

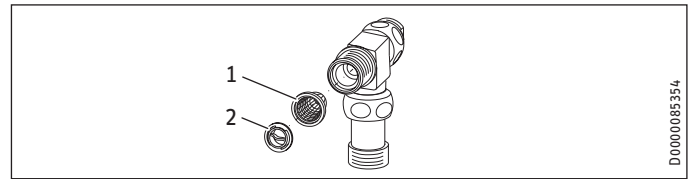

- 1 Strainer
2 Plastic profile washer
- ▶ Fit the strainer and the plastic profile washer in the tee for the cold water inlet.

- !** **Material losses**
The strainer must be fitted for the appliance to function.
- ▶ When replacing the appliance, check that the strainer is present.

Removing the flow limiter

- i** **Note**
If you are using a thermostatic valve, you must not remove the flow limiter.

If the flow rate is too low, remove the flow limiter. To do this, remove the function module from the appliance back panel.

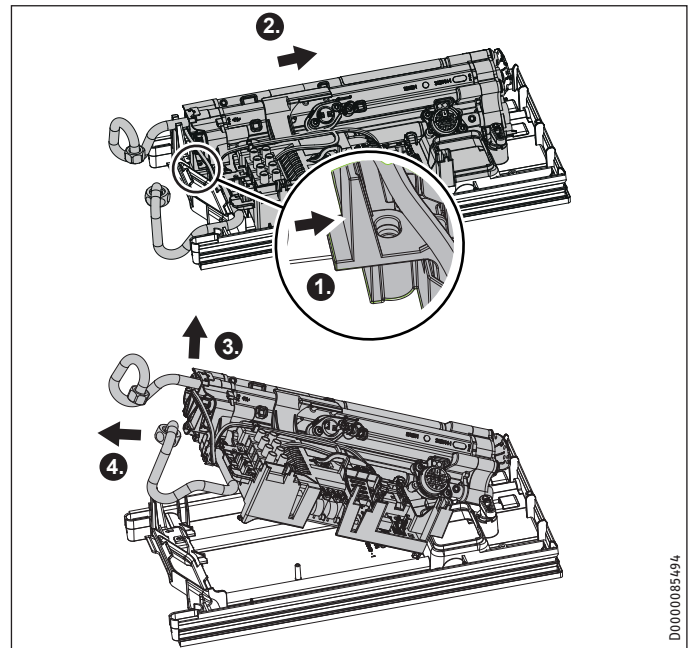

- ▶ Release the locking hook.
- ▶ Push the function module in the appliance back panel slightly towards the back.
- ▶ Remove the function module from the appliance back panel by pulling it slightly forwards and lifting it off.

INSTALLATION

Installation

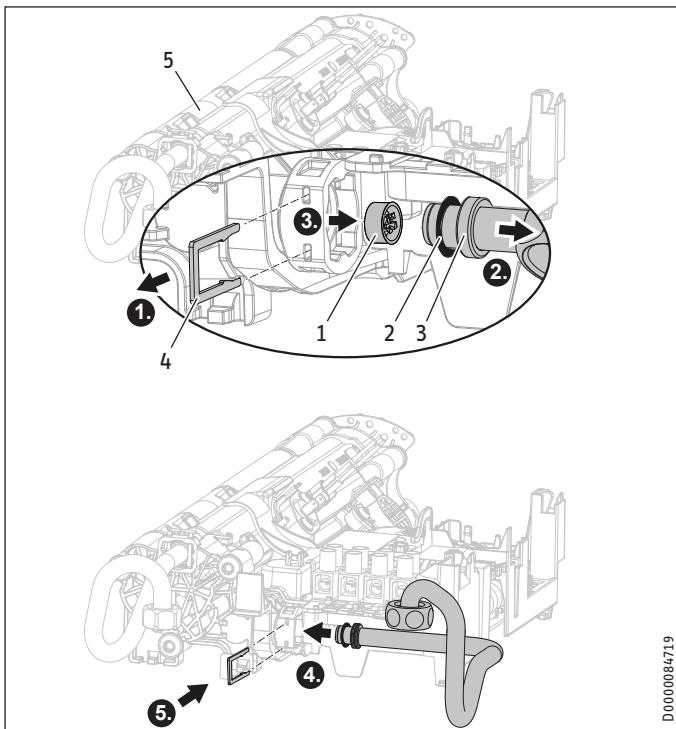

- 1 Flow limiter
- 2 O-ring
- 3 Cold water pipe bend with recess for locking clip
- 4 Locking clip
- 5 Heater

- ▶ Remove the cold water pipe bend and the O-ring.
- ▶ Remove the flow limiter from the cold water inlet of the heater using a pointed object or suitable pliers.
- ▶ Refit the cold water pipe bend and the O-ring.



Material losses

- The O-ring must be fitted to prevent the appliance from leaking.
- ▶ As part of installation, check that the O-ring is in place.

- ▶ Secure the cold water pipe bend with the locking clip.



Material losses

- Ensure that the locking clip is located behind the recess in the pipe bend and fixes the bend in position.

- ▶ Mount the function module in reverse order in the appliance back panel until the function module clicks into place.

Installing the appliance



Note

- If you are installing the appliance with flexible pipe connections, also secure the bottom of the back panel with a screw.

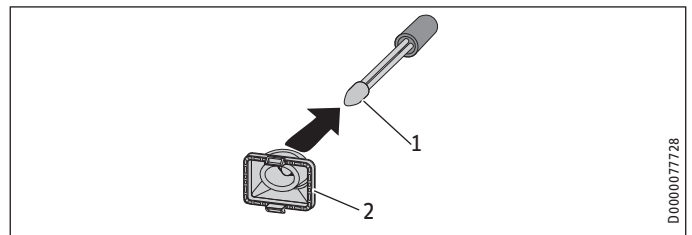

- 1 Cable entry installation aid
- 2 Cable grommet

Use the installation aid for easier wiring access through the cable grommet (see plastic parts set supplied).

- ▶ Remove the cable grommet from the back panel.
- ▶ Pull the cable grommet over the cable sheath of the power cable. For large cable cross-sections, enlarge the hole in the cable grommet if necessary.

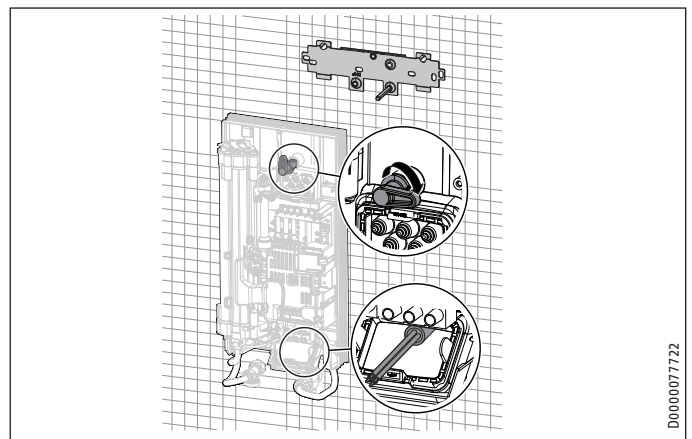

- ▶ Remove the transport protection plugs from the appliance pipe connections.
- ▶ Bend the power cable 45° upwards.
- ▶ Route the power cable and cable grommet through the back panel from the rear.
- ▶ Install the appliance on the threaded studs of the wall mounting bracket.
- ▶ Press the back panel firmly into place, aligning it correctly.
- ▶ Lock the fixing toggle by turning it 90° clockwise.
- ▶ Pull the cable grommets into the back panel, until both locking tabs engage.

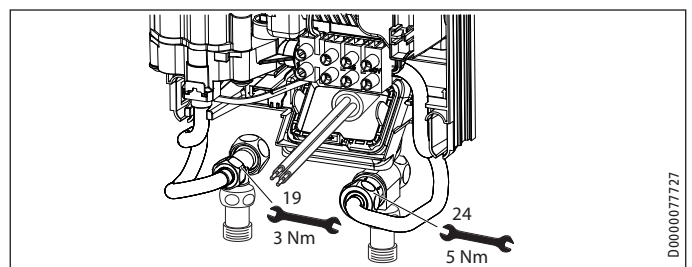

- ▶ Screw the pre-assembled parts with flat gaskets to the cold water and DHW pipes of the appliance.
- ▶ Fit the cold water inlet pipe and the DHW outlet pipe from the pipework with flat gaskets to the extensions from the appliance.

INSTALLATION

Commissioning

Making the electrical connection

WARNING Electrocutation
Carry out all electrical connection and installation work in accordance with relevant regulations.

WARNING Electrocutation
The connection to the power supply must be in the form of a permanent connection in conjunction with the removable cable grommet. Ensure the appliance can be separated from the power supply by an isolator that disconnects all poles with at least 3 mm contact separation.

WARNING Electrocutation
Ensure that the appliance is earthed.

Material losses
Observe the type plate. The specified rated voltage must match the mains voltage.

- ▶ Connect the power cable to the mains terminal.

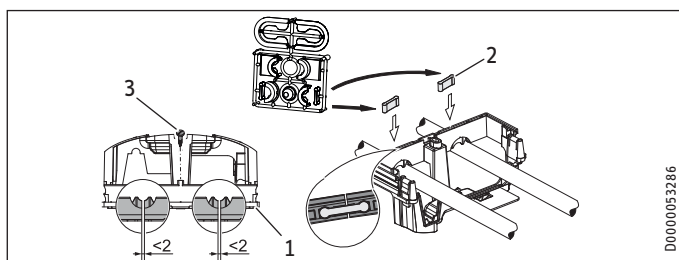

- 1 Lower back panel section
- 2 Connection piece in the standard delivery
- 3 Screw

If using threaded fittings on finished walls, the lower back panel section can also be installed after fitting the taps/valves. To do this, carry out the following steps:

- ▶ Cut open the lower section of the back panel.
- ▶ Fit the lower section of the back panel by bending it out at the sides and guiding it over the pipes.
- ▶ Insert the connection pieces into the lower section of the back panel from behind.
- ▶ Click the lower section of the back panel into place.
- ▶ Secure the lower back panel section with a screw.

Material losses
The cover plate of the lower back panel section must not bend when installed.

11. Commissioning

11.1 Preparation

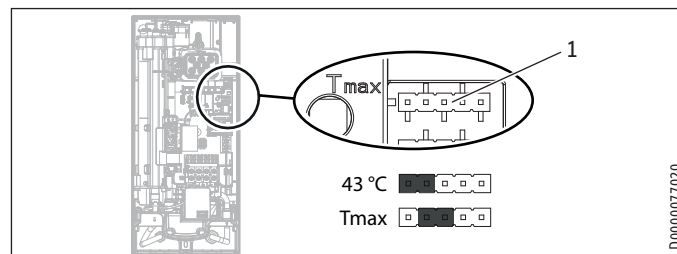

- 1 Jumper for anti-scalding protection setting

Internal anti-scalding protection via jumper slot

Jumper position	Description
43 °C	
Tmax	Factory setting (60 °C)
No jumper	Limited to 43 °C

- ▶ Install the anti-scalding protection setting jumper in the required position on the upper pin strip.

CAUTION Burns
If the appliance is supplied with preheated water, the internal anti-scalding protection may be exceeded.
▶ In such cases, limit the temperature with an upstream central thermostatic valve.

11.2 Initial start-up



- ▶ Open and close all connected draw-off valves several times, until all air has been purged from the pipework and the appliance.
- ▶ Carry out a tightness check.

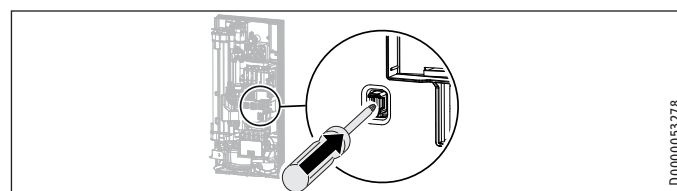

- ▶ Activate the safety switch by firmly pressing the reset button (the appliance is delivered with the safety switch disabled).

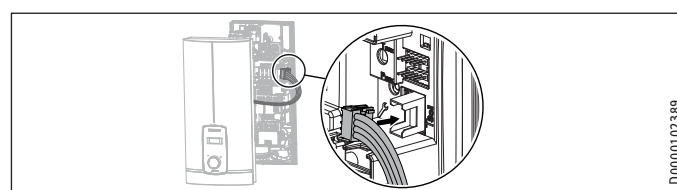

- ▶ Connect the programming unit connecting cable to the PCB.

INSTALLATION

Appliance shutdown



Note

For undersink installation, the appliance cover should be turned round for easier operation; see chapter "Alternative installation methods / Pivoting appliance cover".

Fit the appliance cover

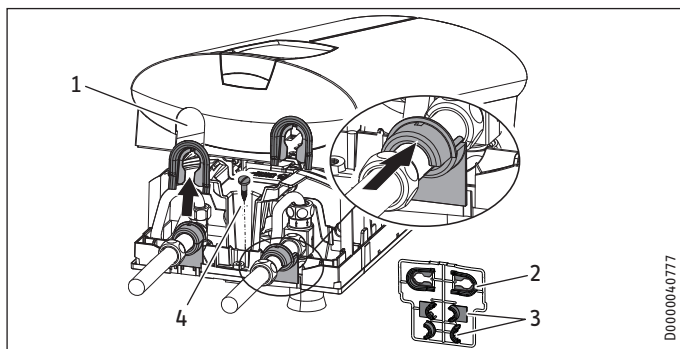

- 1 Pipe knock-out
- 2 Cover guides
- 3 Back panel guides
- 4 Fixing screw (not part of the standard delivery)

► Cleanly cut or break out the knock-out openings in the appliance cover. If necessary, use a file.



Material losses

If you cut open the wrong knock-out in the appliance cover by mistake, you must use a new appliance cover.



Note

You can compensate for a slight connection pipe offset using the tabs on the cover guides. If the connection pipes are offset, do not fit any back panel guides.

- When installing connection pipes without offset, break off the tabs on the cover guide pieces.
- Click the cover guides into place in the openings.
- Position the back panel guides on the extensions. Push them together. Then push the guide pieces against the back panel as far they will go.

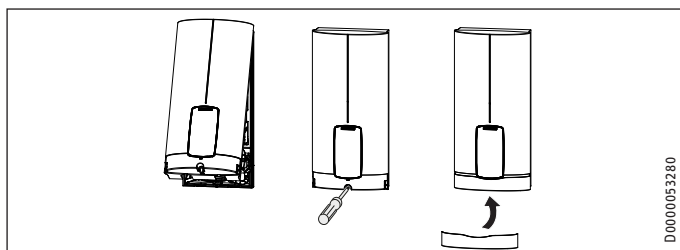

- Pivot the appliance cover downwards. Check that the appliance cover is securely seated at both top and bottom.
- Secure the appliance cover with the screw.
- Fit the fascia to the appliance cover.



on

- Switch on the power supply.

11.2.1 Appliance handover

- Explain the appliance function to users and familiarise them with its operation.
- Make the user aware of potential dangers, especially the risk of scalding.
- Hand over the instructions.

11.3 Recommissioning



Material losses

To ensure that the bare wire heating system is not damaged following an interruption to the water supply, the appliance must be restarted taking the following steps.

- Disconnect the appliance from the power supply by removing the fuses/tripping the MCBs.
- Open the tap for a minimum of one minute until the appliance and its upstream cold water inlet line are free of air.
- Switch the power back ON.

12. Appliance shutdown

- Isolate all poles of the appliance from the power supply.
- Drain the appliance (see chapter "Installation / Maintenance / Draining the appliance").

13. Alternative installation methods

Overview of the alternative types of installation

Electrical connection	IP rating
On unfinished walls, connected from above	IP 25
Unfinished walls, from below, short power cable	IP 25
Installation on finished walls	IP 24
Water connection	IP rating
Installation on unfinished walls	IP 25
Other	IP rating
Installation with offset tiles	IP 25
Pivoting appliance cover	IP 25
Horizontal installation of the appliance	IP 24



WARNING Electrocutation

Before any work on the appliance, disconnect all poles from the power supply.

13.1 Electrical connection from above on unfinished walls

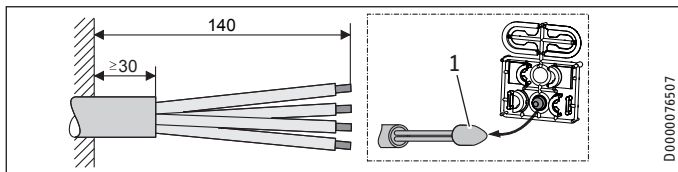

1 Cable entry installation aid

- Prepare the power cable.

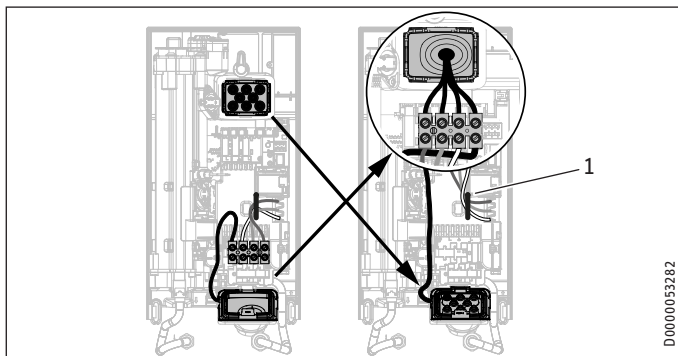

1 Cable routing

- Reposition the mains terminal from the bottom to the top. To do this, undo the fixing screw. Turn the mains terminal with connecting cables 180° clockwise. Route the cable around the cable guide when doing so. Secure the mains terminal in place.
- Replace the cable grommets.
- Install the cable grommet downwards from above.
- Pull the cable grommet over the cable sheath of the power cable.
- Install the appliance on the threaded studs of the wall mounting bracket.
- Push the back panel firmly against the wall. Lock the fixing toggle by turning it 90° clockwise.
- Pull the cable grommets into the back panel, until both locking tabs engage.
- Connect the power cable to the mains terminal.



WARNING Electrocutation

The connecting wires must not protrude beyond the level of the mains terminal.

13.2 Electrical connection on unfinished walls with short power cable

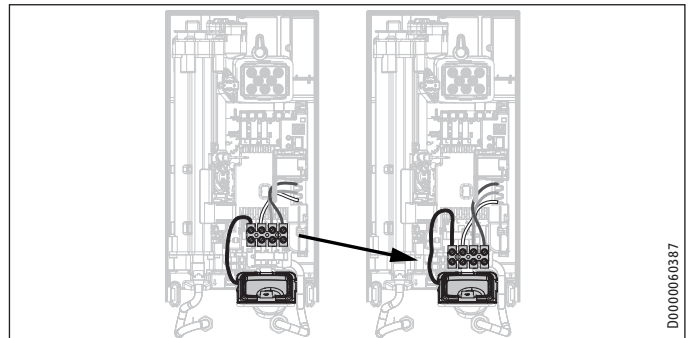

- Reposition the mains terminal further downwards. To do this, undo the fixing screw. Secure the mains terminal in place.

13.3 Electrical connection on finished walls



Note

This type of connection changes the IP rating of the appliance.

- Change the type plate. Cross out "IP 25" and mark the box "IP 24". Use a ballpoint pen to do this.

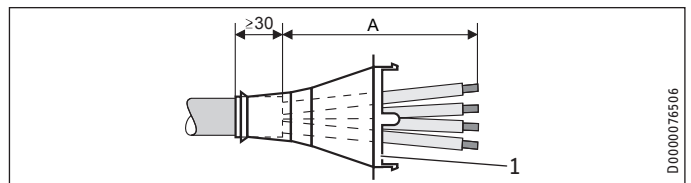

1 Cable grommet

Dimension A Electrical connection on finished walls

160 Positioned in lower section of appliance

110 Positioned in upper section of appliance

- Prepare the power cable. Fit the cable grommet.



Material losses

If you break out the wrong knock-out in the back panel/appliance cover by mistake, you must use a new back panel/appliance cover.

- Cleanly cut and break out the required cable entries from the back panel and appliance cover (for the positions, see chapter "Specification / Dimensions and connections"). Deburr any sharp edges with a file.
- Route the power cable through the cable grommet.
- Connect the power cable to the mains terminal.



Note

If the appliance is rated IP 24, amend the appliance type plate.

- Cross out "IP 25" and mark the box "IP 24". Use a ballpoint pen to do this.

INSTALLATION

Alternative installation methods

13.4 Water installation on unfinished walls

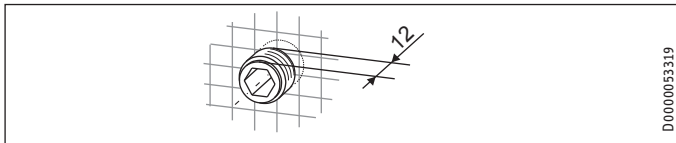

- ▶ Seal and screw in the twin connectors (not included in standard delivery).

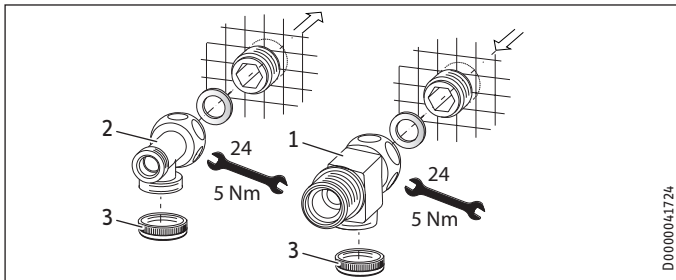

- 1 Tee for cold water
 - 2 Tee for domestic hot water
 - 3 Cap
- ▶ Fit the water connections.

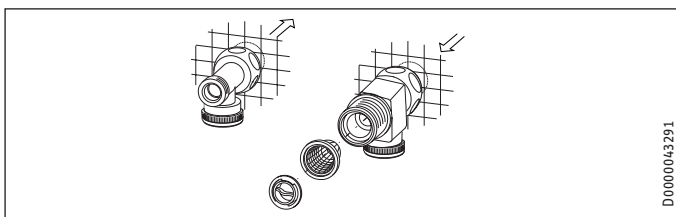

- ▶ Fit the strainer and the plastic profile washer in the tee for the cold water inlet.



Material losses

- The strainer must be fitted for the appliance to function.
- ▶ When replacing the appliance, check that the strainer is present.

- ▶ Screw the connection pipes from the appliance to the tee.
- ▶ Open the shut-off valve in the cold water inlet line.

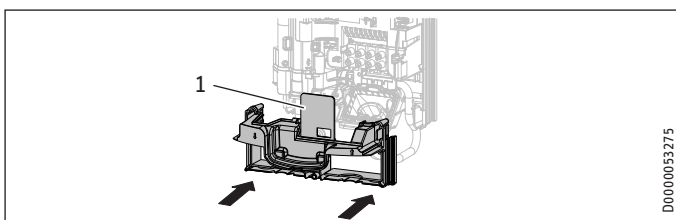

- 1 Diffuser on lower back panel
- ▶ Fit the lower back panel section into the back panel. Check that both locking tabs are engaged.
 - ▶ Align the mounted appliance by undoing the fixing toggle, aligning the power supply and back panel, and then re-tightening the fixing toggle. If the back panel does not sit flush against the wall, you can secure the appliance at the bottom with an additional screw.



Material losses

- The cover plate of the lower back panel section must not bend when installed.

13.5 Wall mounting bracket when replacing appliance

An existing STIEBEL ELTRON wall mounting bracket may be used when replacing appliances (except for DHF instantaneous water heater), as long as the fixing screw is in the lower right position.

Replacing a DHF instantaneous water heater

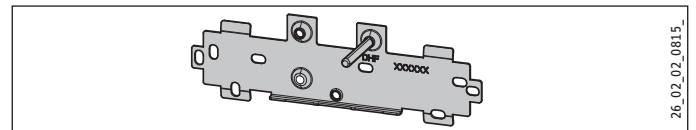

- ▶ Reposition the fixing screw on the wall mounting bracket (the securing screw has a self-tapping thread).
- ▶ Rotate the wall mounting bracket 180° and mount it on the wall (the DHF logo is then turned towards the reader).

13.6 Installation with offset tiles

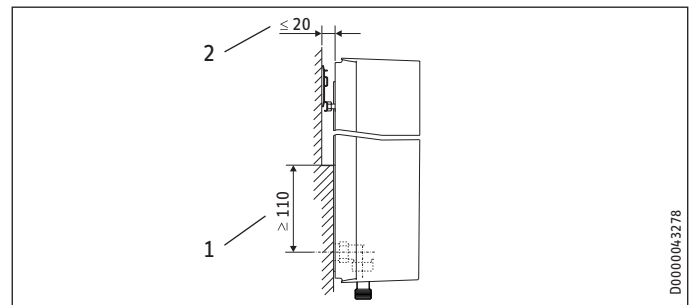

- 1 Minimum contact area of the appliance
 - 2 Maximum tile offset
- ▶ Adjust the wall clearance. Lock the back panel in place using the fixing toggle (turn 90° clockwise).

13.7 Pivoting appliance cover

The appliance cover should be turned round for undersink installation.

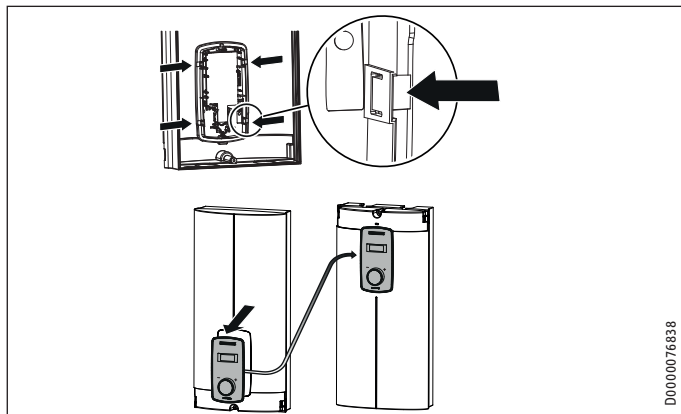

- ▶ Remove the programming unit from the appliance cover by pressing the locking hooks and removing the programming unit.
- ▶ Turn the appliance cover (not the appliance) and refit the programming unit. Push the programming unit home in parallel until all locking tabs engage. When engaging the locking tabs, apply counter pressure by pushing against the appliance cover from the inside.



WARNING Electrocutation

All 4 locking tabs on the programming unit must click into place. The locking tabs must be complete and undamaged. If the programming unit is not inserted correctly, protection of users against contact with live components cannot be ensured.

- ▶ Insert the connecting cable plug of the programming unit into the PCB (see chapter "Commissioning / Initial start-up").
- ▶ Hook the appliance cover in at the bottom. Pivot the appliance cover up to the back panel.
- ▶ Secure the appliance cover.
- ▶ Fit the cover on to the appliance cover.

13.8 Operation with preheated water

You can restrict the maximum inlet temperature by installing a central thermostatic valve.

13.9 Horizontal installation of the appliance



Note

For the horizontal installation alternative, please note the following points:

- Installation is only permissible with direct wall mounting.
- The installation versions "Installation with offset tiles" and "Rotated appliance cover" are not permissible.
- This type of connection changes the IP rating of the appliance. Cross out "IP 25" on the type plate and mark the box "IP 24". Use a ballpoint pen to do this.

Horizontal installation

The appliance can also be mounted horizontally on the wall (turned 90° to the left, with the water connections on the right). The installation, water and electrical connections are described in chapters "Standard installation" and "Installation alternatives".

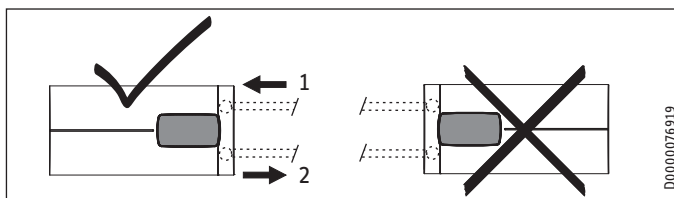

- 1 Cold water inlet
- 2 DHW outlet

Preparation

The appliance cover must be provided with a condensate drain opening of min. \varnothing 5.0 mm to max. \varnothing 6.0 mm at the marked position.

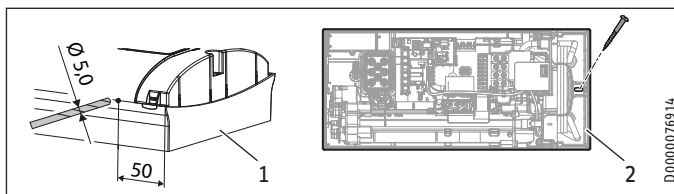

- 1 Appliance cover with opening for condensate drain
 - 2 Back panel with additional fixing screw
- ▶ Drill a hole from the outside through the dismantled appliance cover at the marked point. Alternatively, you can punch a hole in the appliance cover from the inside at the marked point. In this case, you must then enlarge the hole to the required diameter from the outside. Deburr any sharp edges with a file.
 - ▶ Secure the appliance back panel with an additional screw.



Material losses

An appliance cover with an existing condensate drain opening must no longer be used for vertical installation of the appliance.

14. Service information

Overview of connections

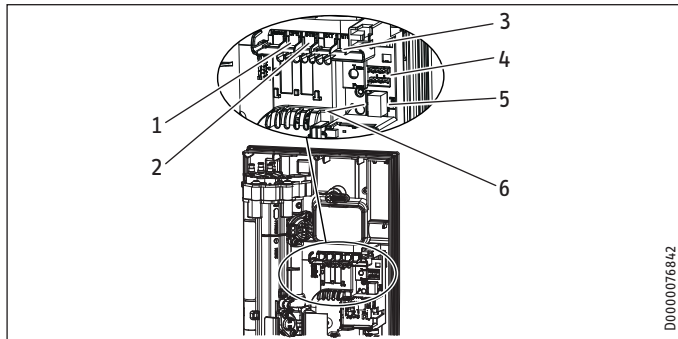

- 1 Flow sensor
- 2 High limit safety cut-out, automatic reset
- 3 NTC sensor
- 4 Pin strip for anti-scalding protection
- 5 Programming unit plug-in position
- 6 Diagnostic traffic light

Appliance cover retainer

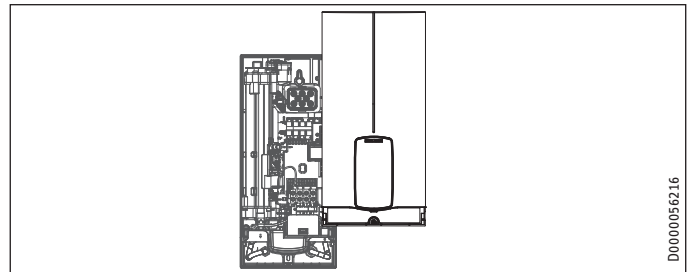

15. Troubleshooting



WARNING Electrocutation
To test the appliance, it must be connected to the power supply.



Note
When testing the appliance using the diagnostic traffic lights, water must be flowing.

Indicator options for diagnostic traffic light (LED)

	Red	Illuminates in the event of a fault
	Yellow	Illuminates in heating mode/flashes when output restriction reached
	Green	Flashing: Appliance connected to power supply

Diagnostic traffic lights (draw-off mode)	Fault	Cause	Remedy
No LED illuminates	Appliance does not heat up	One or more mains power phases missing Faulty PCB	Check fuses/MCBs in distribution board Replacing the function module
Green flashing, yellow off, red off	No DHW	Appliance starting flow rate not reached; shower head/aerator scaled up Appliance starting flow rate not reached; strainer in cold water inlet dirty Flow meter not attached Flow meter faulty or dirty Faulty PCB	Descale/replace the shower head/aerator Cleaning the strainer Check plug-in connection; correct if necessary Replacing the flow meter Replacing the function module
Green flashing, yellow on, red off	No display	Loose connecting cable between PCB and programming unit Faulty connecting cable between PCB and programming unit Programming unit faulty Faulty PCB	Check plug-in connections; correct if necessary Check connecting cable; replace if necessary Replacing the programming unit Replacing the function module
Green flashing, yellow on, red off	No DHW; outlet temperature does not match set value	Tap faulty Faulty outlet sensor Heating system faulty Faulty PCB	Replace tap Replace the outlet sensor Replacing the function module Replacing the function module
Green flashing, yellow flashing, red off	No DHW; outlet temperature does not match set value	Appliance is operating at its output limit Appliance is operating at its output limit Heating system faulty	Reduce flow rate; install flow limiter Check jumper position for connected load Replacing the function module

INSTALLATION

Maintenance

Diagnostic traffic lights (draw-off mode)	Fault	Cause	Remedy
Green flashing, yellow off, red on	No DHW; outlet temperature does not match set value	One or more mains power phases missing	Check fuses/MCBs in distribution board
		Air detection has responded	Continue draw-off for >1 min
		Safety switch not activated during "Commissioning"	Activate safety switch by pressing the reset button firmly
		Safety switch triggered by high limit safety cut-out	Check high limit safety cut-out (plug-in connection, connecting cable); activate safety switch
		Safety switch responds again after high limit safety cut-out has been checked; high limit safety cut-out faulty	Replace high limit safety cut-out; activate safety switch and draw off water at the maximum set value for >1 min
		Safety switch responds again; PCB faulty	Replacing the function module
		Short circuit in outlet sensor	Check outlet sensor; replace if necessary
		Faulty PCB	Replacing the function module

16. Maintenance



WARNING Electrocutation

Before any work on the appliance, disconnect all poles from the power supply. This appliance contains capacitors which are discharged when disconnected from the power supply. The capacitor discharge voltage may briefly exceed 60 V DC.

Draining the appliance

The appliance can be drained for maintenance work.



WARNING Burns

Hot water may escape when you drain the appliance.

- ▶ Close the shut-off valve in the cold water inlet line.
- ▶ Open all draw-off valves.
- ▶ Undo the pipe connections from the appliance.
- ▶ Store the dismantled appliance in a room free from the risk of frost, as water residues remaining inside the appliance can freeze and cause damage.

Cleaning the strainer

If dirty, clean the strainer in the threaded cold water fitting. Close the shut-off valve in the cold water inlet line before removing, cleaning and refitting the strainer.

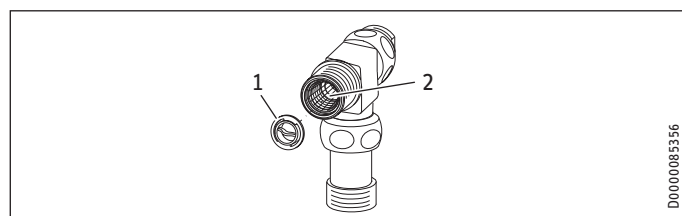

- 1 Plastic profile washer
- 2 Strainer

- ▶ Remove the plastic profile washer.
- ▶ Remove the strainer and clean the components.
- ▶ Fit the strainer and the plastic profile washer.

17. Specification

17.1 Dimensions and connections

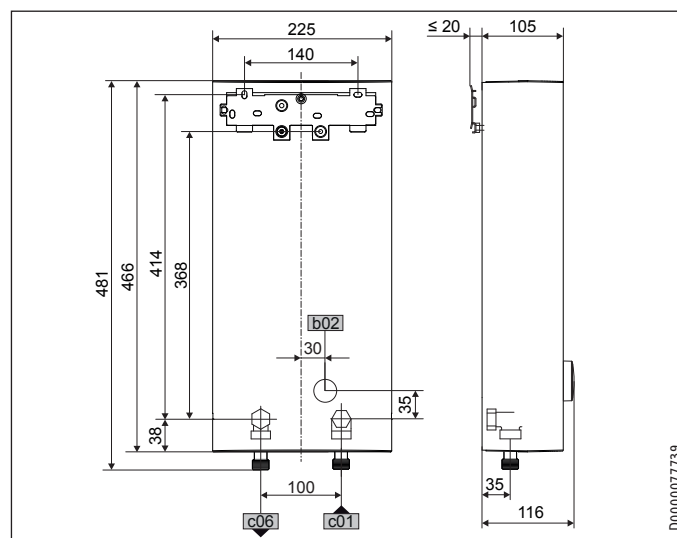

		DHB-E LCD AU
b02	Entry electrical cables I	On unfinished walls
c01	Cold water inlet	Male thread G 1/2 A
c06	DHW outlet	Male thread G 1/2 A

INSTALLATION Specification

Alternative connection options

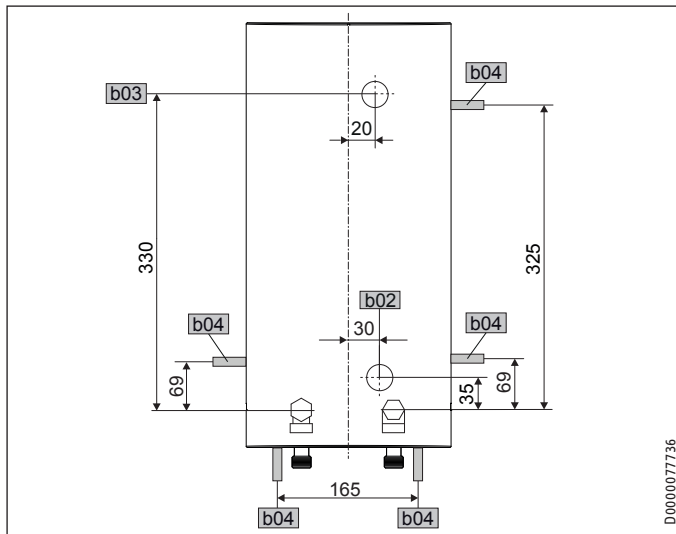

		DHB-E LCD AU
b02	Entry electrical cables I	On unfinished walls
b03	Entry electrical cables II	On unfinished walls
b04	Entry electrical cables III	On finished walls

17.2 Wiring diagram

3/PE ~ 380-415 V

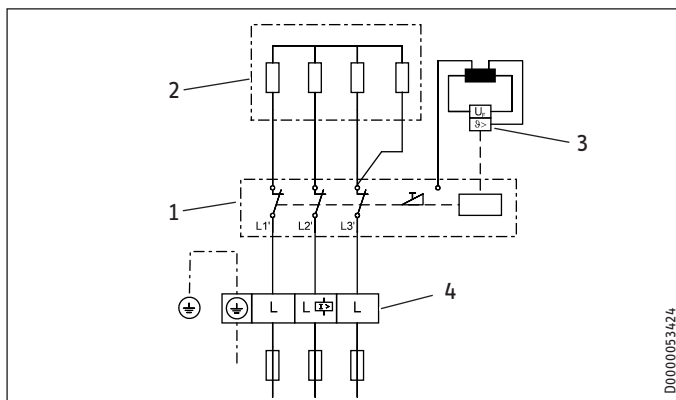

- 1 Power PCB with integral safety switch
- 2 Bare wire heating system
- 3 High limit safety cut-out
- 4 Mains terminal

17.3 Domestic hot water output

The DHW output is subject to the connected power supply, the appliance's connected load and the cold water inlet temperature. The rated voltage and rated output can be found on the type plate.

Connected load in kW	38 °C DHW output in L/min.			
	Rated voltage	Cold water inlet temperature		
	380 V	400 V	415 V	
				5 °C
				10 °C
				15 °C
				20 °C
DHB-E 13 LCD AU	12.2			5.3
		13.5		6.2
			14.5	7.6
				9.7
				5.8
				6.9
				8.4
				10.7
				6.3
				7.4
				9.0
				11.5

Connected load in kW	38 °C DHW output in L/min.			
	Rated voltage	Cold water inlet temperature		
	380 V	400 V	415 V	
				5 °C
				10 °C
				15 °C
				20 °C
DHB-E 18 LCD AU	16.2			7.0
		18		8.3
			19.4	10.1
				12.9
DHB-E 27 LCD AU				7.8
				9.2
				11.2
				14.3
				8.4
				9.9
				12.0
				15.4

Connected load in kW	50 °C DHW output in L/min.			
	Rated voltage	Cold water inlet temperature		
	380 V	400 V	415 V	
				5 °C
				10 °C
				15 °C
				20 °C
DHB-E 13 LCD AU	12.2			3.9
		13.5		4.4
			14.5	5.0
				5.8
DHB-E 18 LCD AU				4.3
				4.8
				5.5
				6.4
				4.6
				5.2
				5.9
				6.9
DHB-E 27 LCD AU				5.1
				5.8
				6.6
				7.7
				5.7
				6.4
				7.3
				8.6
				6.2
				6.9
				7.9
				9.2
				7.5
				8.4
				9.6
				11.2
				8.3
				9.3
				10.6
				12.4
				8.9
				10.0
				11.4
				13.3

17.4 Application areas / Conversion table

Specific electrical resistance and specific electrical conductivity

Standard specification at 15 °C	20 °C		25 °C	
	Resistance $\rho \geq$	Conductivity $\sigma \leq$	Resistance $\rho \geq$	Conductivity $\sigma \leq$
	$\Omega \text{ cm}$	$\mu\text{S/cm}$	$\Omega \text{ cm}$	$\mu\text{S/cm}$
	900	111	800	1250
		1111	125	1250
			735	136
				1361

17.5 Pressure drop

Taps/valves

Tap pressure drop at a flow rate of 10 L/min	
Mono lever mixer tap, approx.	MPa 0.04 - 0.08
Thermostatic valve, approx.	MPa 0.03 - 0.05
Shower head, approx.	MPa 0.03 - 0.15

Sizing the pipework

When calculating the size of the pipework, an appliance pressure drop of 0.1 MPa is recommended.

17.6 Fault conditions

In the event of a fault, loads up to 80 °C at a pressure of 1.0 MPa can occur very briefly in the installation.

17.7 Data table

		DHB-E 13 LCD AU			DHB-E 18 LCD AU			DHB-E 27 LCD AU		
		236747			236748			236749		
Electrical data										
Rated voltage	V	380	400	415	380	400	415	380	400	415
Rated output	kW	12.2	13.5	14.5	16.2	18	19.4	23.5	26	28
Rated current	A	18.5	19.5	20	24.7	26	27	35.6	37.7	38.9
Fuses	A	20	20	20	25	25	32	40	40	40
Frequency	Hz	50/60	50/60	50/-	50/60	50/60	50/-	50/-	50/-	50/-
Phases		3/PE			3/PE			3/PE		
Specific resistance $\rho_{15} \geq$	Ω cm	900			900			900		
Specific conductivity $\sigma_{15} \leq$	$\mu\text{S}/\text{cm}$	1111			1111			1111		
Max. mains impedance	Ω	0.459	0.436	0.42	0.331	0.315	0.304	0.221	0.21	
Versions										
Heating system heat generator		Bare wire			Bare wire			Bare wire		
Adjustable connected load		-			-			-		
Temperature setting range	$^{\circ}\text{C}$	Off, 20-60			Off, 20-60			Off, 20-60		
Protection class		1			1			1		
Insulating block		Plastic			Plastic			Plastic		
Cover and back panel		Plastic			Plastic			Plastic		
IP rating		IP25			IP25			IP25		
Colour		White			White			White		
Connections										
Water connection		G 1/2 A			G 1/2 A			G 1/2 A		
Application limits										
Max. permissible pressure	MPa	1			1			1		
Max. inlet temperature for reheating	$^{\circ}\text{C}$	55			55			55		
Values										
Max. inlet temperature (e.g. pasteurisation)	$^{\circ}\text{C}$	70			70			70		
ON	l/min	>2.5			>2.5			>2.5		
Flow rate limit at	l/min	8			9			9		
Flow rate at 28 K	l/min	7.4 at 415 V			9.9 at 415 V			14.3 at 415 V		
Flow rate at 50 K	l/min	4.2 at 415 V			5.6 at 415 V			8.0 at 415 V		
Pressure drop for flow rate at 50 K (without flow limiter)	MPa	0.04			0.06			0.14		
Pressure drop for flow rate at 50 K (with flow limiter)	MPa	0.07			0.12			0.22		
Hydraulic data										
Nominal capacity	l	0.4			0.4			0.4		
Dimensions										
Height	mm	466			466			466		
Width	mm	225			225			225		
Depth	mm	116			116			116		
Weights										
Weight	kg	2.9			2.9			2.9		



Note

The appliance conforms to IEC 61000-3-12.

Information on the appliance software

Stiebel Eltron appliances may contain software of external suppliers (third party suppliers) which may be partly also be subject to an Open Source license. Some Open Source licenses are subject to the obligation to state the software, its authors as well as the licenses that apply to the software and to additionally provide the software as a source code or to offer to provide the source code. Stiebel Eltron therefore provides further information regarding third supplier software that it uses under the link <https://www.stiebel-eltron.com/en/info/Licenses.html> and also offers the source code there, if applicable. The software is provided only for compliance with the obligations under the Open Source licenses.

Environment and recycling

► Dispose of the appliances and materials after use in accordance with national regulations.



► If a crossed-out waste bin is pictured on the appliance, take the appliance to your local waste and recycling centre or nearest retail take-back point for reuse and recycling.



This document is made of recyclable paper.

► Dispose of the document at the end of the appliance's life cycle in accordance with national regulations.

WARRANTY

Who gives the warranty

1. The warranty is given by Stiebel Eltron (Aust) Pty Ltd (A.B.N. 82 066 271 083) of 294 Salmon Street, Port Melbourne, Victoria, 3207 ("we", "us" or "our").

The warranty

2. This warranty applies to the Stiebel Eltron Water Heaters - WaterMark Approved (the "unit") listed within this operating and installation guide manufactured after 1 July 2023.
3. Subject to the warranty exclusions we will repair or replace, at our absolute discretion, a faulty component in your unit free of charge if it fails to operate in accordance with its specifications during the warranty period.
4. If we repair or replace a faulty component to your unit under this warranty, the warranty period is not extended from the time of the repair or replacement. The repaired part will be warranted for an additional 12 months from installation or for the remaining duration of original warranty.
5. The warranty period commences on the date of completion of the installation of the unit. Where the date of completion of installation is not known, then the warranty period will commence 2 months after the date of manufacture.
6. The warranty period for a unit used for domestic purposes is shown in the table below. Domestic purposes means that the unit is used in a domestic dwelling.

Component	Warranty period
All components	7 years from the date of completion of the installation of the unit.

7. The warranty period for a unit used for commercial purposes is shown in the table below. Commercial purposes means that the unit is used for a non-domestic purpose and includes but not limited to being used in a motel, hotel, mining camp or nursing home.

Component	Warranty period
All components	1 year from the date of completion of the installation of the unit.

Your entitlement to make a warranty claim

8. You are entitled to make a warranty claim if:
 - 8.1. you own the unit or if you have the owner's consent to represent the owner of the unit;
 - 8.2. you contact us within a reasonable time of discovering the problem with the unit;

How you make a warranty claim

9. To make a warranty claim you must provide us with the following information:
 - 9.1. The model number of the unit;
 - 9.2. A description of the problem with the unit;
 - 9.3. The name, address and contact details (such as phone number and e-mail address) of the owner;
 - 9.4. The address where the unit is installed and the location (e.g. in laundry);
 - 9.5. The serial number of the unit;
 - 9.6. The date of purchase of the unit and the name of the seller of the unit;
 - 9.7. The date of installation of the unit;
 - 9.8. A copy of the certificate of compliance when the unit was installed.
10. The contact details for you to make your warranty claim are:

Name: Stiebel Eltron (Aust) Pty Ltd
Address: 294 Salmon Street, Port Melbourne, Victoria, 3207
Telephone: 1800 153 351
(8.00 am to 5.00 pm AEST Monday to Friday)
Contact person: Customer Service Representative
E-mail: service@stiebel-eltron.com.au
11. We will arrange a suitable time with you to inspect and test the unit.

Warranty exclusions

12. We may reject your warranty claim if:
 - 12.1. The unit was not installed by registered and qualified tradespeople.
 - 12.2. The unit was not installed and commissioned:
 - (a) in Australia;
 - (b) in accordance with the Operating and Installation Guide; and

- (c) in accordance with the relevant statutory and local requirements of the State or Territory in which the unit is installed.
- 12.3. The unit has not been operated or maintained in accordance with the Operating and Installation Guide.
- 12.4. The unit does not bear its original Serial Number for Rating Label.
- 12.5. The unit was damaged by any or any combination of the following:
 - (a) normal fair wear and tear;
 - (b) connection to an incorrect water supply;
 - (c) connection to water from a bore, dam or swimming pool;
 - (d) connection to an incorrect power supply;
 - (e) connection to faulty equipment, such as damaged valves;
 - (f) foreign matter in the water supply, such as sludge or sediment;
 - (g) corrosive elements in the water supply;
 - (h) accidental damage;
 - (i) act of God, including damage by flood, storm, fire, lightning strike and the like;
 - (j) excessive water pressure, negative water pressure (partial vacuum) or water pressure pulsation;
 - (k) ingress of vermin.
- 12.6. The unit was damaged before it was installed e.g. it was damaged in transit.
- 12.7. An unauthorised person has modified, serviced, repaired or attempted to repair the unit without our consent.
- 12.8. Non genuine parts other than those manufactured or approved by us have been used on the unit.
13. We may charge you:
 - 13.1. for any additional transport costs if the unit is installed more than 30 kilometres from our closest authorised service technician.
 - 13.2. for the extra time it takes our authorised service technician to access the unit for inspection and testing if it is not sited in accordance with the Operating and Installation Guide and not readily accessible for inspection.
 - 13.3. for any extra costs of our authorised service technician to make the unit safe for inspection.
14. You must ensure that access to the unit by our authorised service technician is safe and free from obstruction.
15. Our authorised service technician may refuse to inspect and test the unit until you provide safe and free access to it, at your cost.
16. If we reject your warranty claim in accordance with clause 12, we may charge you for our authorised service technician's labour costs to inspect and test the unit.
17. In order to properly test the unit we may remove it to another location for testing.

Australian Consumer Law

18. Our goods come with guarantees that cannot be excluded under the Australian Consumer Law. You are entitled to a replacement or refund for a major failure and compensation for any other reasonably foreseeable loss or damage. You are also entitled to have the goods repaired or replaced if the goods fail to be of acceptable quality and the failure does not amount to a major failure.
19. The Stiebel Eltron warranty for the unit is in addition to any rights and remedies you may have under the Australian Consumer Law.

Comfort through Technology

STIEBEL ELTRON International GmbH

Dr.-Stiebel-Straße 33 | 37603 Holzminden | Germany
info@stiebel-eltron.com | www.stiebel-eltron.com



A 328226-45503-9853
B 328227-45503-9853