

STIEBEL ELTRON

SHP-0 Plus Hot Water Heat Pump

High efficiency, low impact – R290 refrigerant and WiFi control

100
YRS
OF INNOVATION

50
YRS
OF HEAT PUMPS

30
YRS
IN AUSTRALIA



Climate Friendly with Maximum Savings

This sleek, reliable heat pump delivers efficient hot water while reducing the reliance on traditional element storage or gas fossil fuel by harnessing ambient air heat. It uses eco-friendly R290 refrigerant and maximises energy savings, which can be even further extended when combined with a solar PV generation. With built-in WLAN connectivity, you can monitor & control remotely via the MyStiebel App. Installers can also adjust settings via the Servicewelt App, often without the need for a site visit. With over 50 years of Heat Pumps, you can trust STIEBEL ELTRON and European engineering.

Product features

- › 200L or 300L variants
- › R290 refrigerant with low GWP
- › Control & monitor via MyStiebel App
- › Installer control via Servicewelt App
- › Operates to -6°
- › Solar PV compatible (up to 75°)
- › Quiet operation
- › Hygiene program
- › Timer controls

Warranty

- › 7 years cylinder
- › 5 years sealed refrigeration circuit
- › 2 years all other components

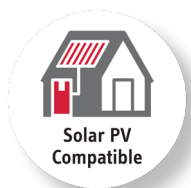

Intelligent Control

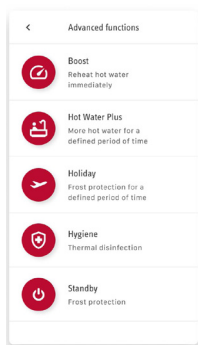

Advanced Functions



Water Comfort

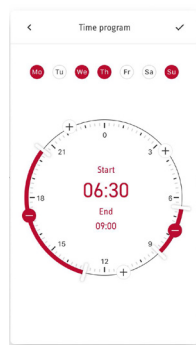

Time Program

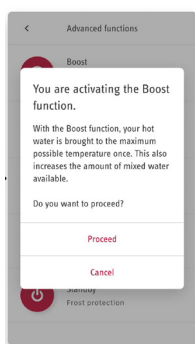

Boost Mode

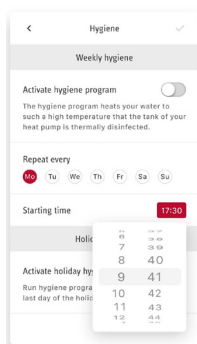

Hygiene Cycle

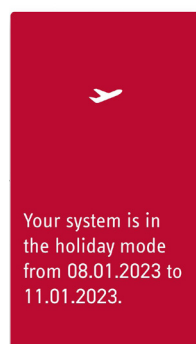

Holiday Mode

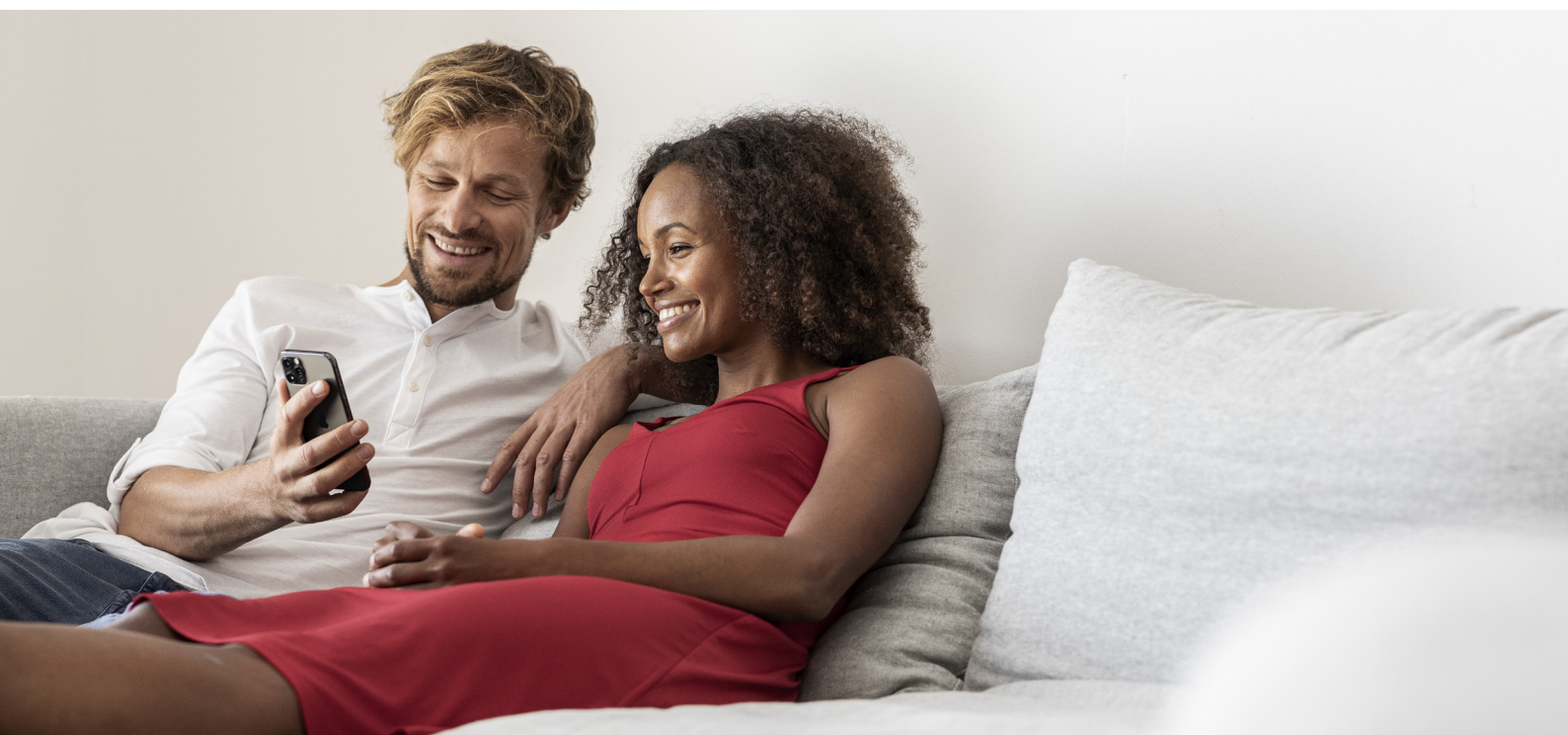

SHP-O 200/300 Plus

HOT WATER HEAT PUMP

Type	SHP-O 200 Plus	SHP-O 300 Plus
Article no.	204472	204473
Height x diameter	mm 1478 x 650	1903 x 650
Weight (empty)	kg 98	117
Weight (filled)	kg 304	422
Nominal capacity	L 200	300
Min/Max application limits	-6 / +43°C	-6 / +43°C
Power supply	1/N/PE 220-240 V 50 Hz	1/N/PE 220-240 V 50 Hz
Average power consumption, heat pump (230 V) (A19/W15-61 I AS/NZS 5125.1)	kW 0.45	0.44
Auxiliary heater power consumption	kW 1.5	1.5
Max. operating current v	A 9.88	9.88
Hot water outlet	G 1	G 1
PTR valve	kPa 850	850
Energy efficiency class	A+	A+
Refrigerant	R290 (152g)	R290 (152g)
GWP	0.02 (IPCC)	0.02 (IPCC)
Timer	Functionality via app	Functionality via app
Average sound pressure level at 2m distance, free field (EN 12102)	dB(A) 53	53
COP (EN16147 / A20)	4.27	4.21

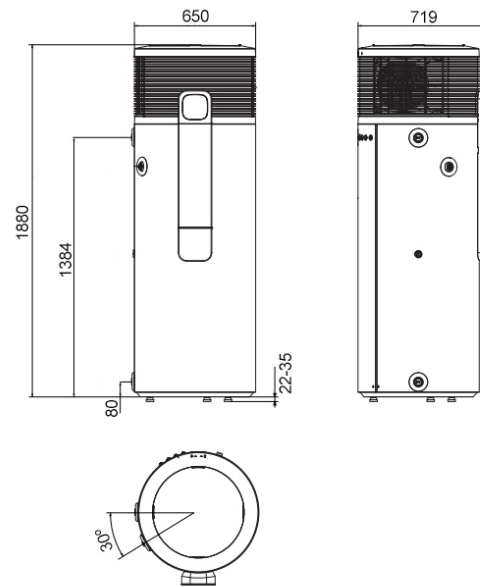
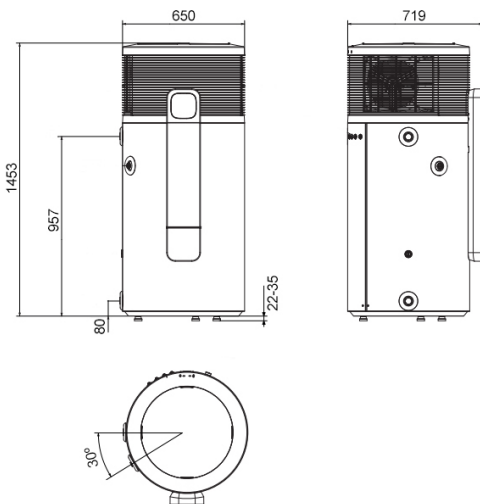
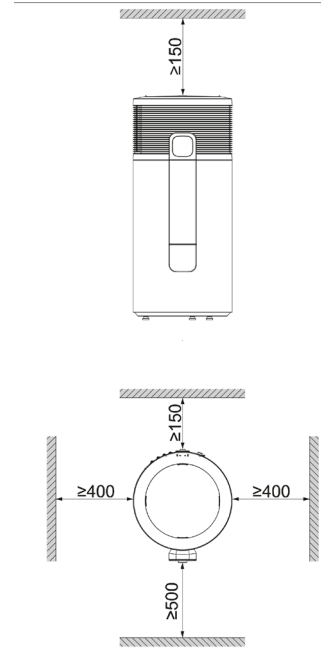

Visit our website
to view our range
of heat pumps



stiebel-eltron.com.au/heat-pumps
1800 153 351

STIEBEL ELTRON is committed to our policy of continual improvement, some features may have subsequently been changed or even removed. Our advisors will be happy to consult with you regarding the currently applicable equipment features. The images used in this data sheet are for reference only.

SHP-O Plus Brochure | Issue 1 | July 2026. Errors Expected. Subject to Changes.

Need Something Larger? See our
Ground & Air Source Heat Pumps

