

Commercial Hot Water Solutions

Energy efficient project solutions

100YRS
OF INNOVATION

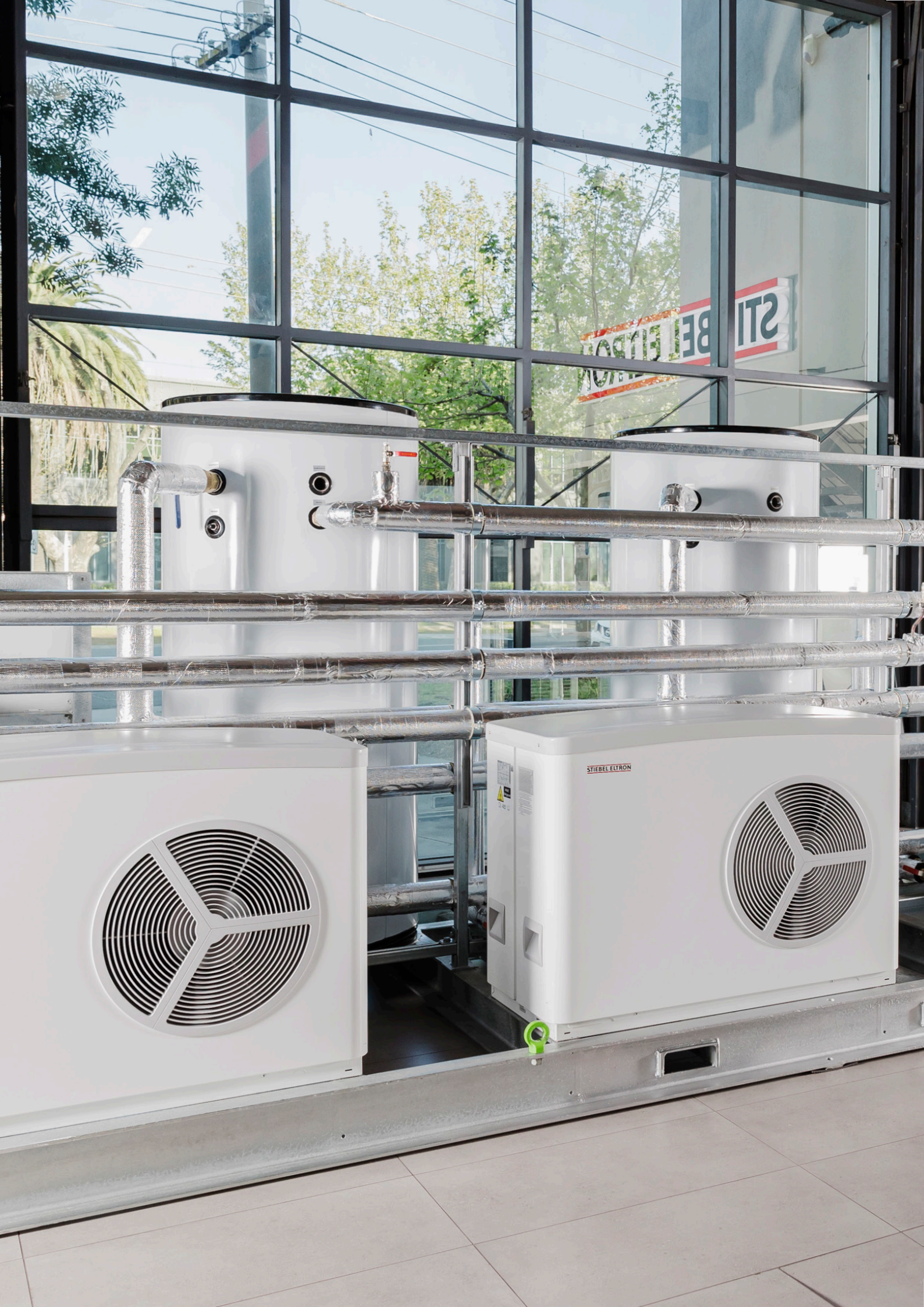



STIEBEL ELTRON

STIEBEL ELTRON



Contents

Our Commitment	04
System Overview	05
Package Sizing	05
Features & Benefits	06

Commercial Integrated (CI) 08

Utilize cascaded WWK heat pumps with built-in tanks to deliver compact solutions for small to medium hot water loads. These systems prioritize flexibility, reliability, and easy installation, making them ideal for limited spaces and applications requiring rapid deployment.

Commercial Modular Trend (CMT) 18

Feature WPL-A 07 monobloc heat pumps paired with stainless steel tanks for outdoor installations. These systems are scalable for medium to large applications, designed to handle varying water conditions with exceptional durability and efficiency, suitable for both new builds and retrofits.

Commercial Modular Premium (CMP) 28

Offers WPL-A 07 heat pumps with high-performance enamel steel tanks featuring ultra-efficient insulation and removable jackets. These systems are ideal for indoor installations with constrained spaces and access, delivering tailored solutions for retrofits and challenging plant room layouts.

Our Commitment

100 years of experience you can rely on

Disclaimer

At STIEBEL ELTRON, we are committed to leading the decarbonization of the commercial hot water industry with innovative, efficient, and robust heat pump solutions. With decades of expertise in heat pump technology and engineering, we deliver advanced systems that are not only reliable but also purpose-built for seamless installation and integration into modern energy management systems.

Our commercial hot water packages stand out for their unmatched efficiency, achieved through meticulous engineering that addresses critical yet often overlooked factors, such as hydronic system balancing and precision-designed plumbing components. Whether pre-manufactured on skids for rapid deployment or installed on-site for tailored configurations, our solutions offer the flexibility to adapt to diverse project requirements.

By combining cutting-edge technology with a deep understanding of real-world challenges, STIEBEL ELTRON provides adaptable, future-ready systems that empower businesses to achieve sustainability goals without compromising performance or reliability.

Enquiry and Qualification

Our sales team will engage with you to understand your objectives. We'll gather detailed information about your project goals, site specifics and budget. Based on your needs, our sales team will present a tailored solution.

Planning and Design

Our design planning team will further refine the solution based on your project objectives, incorporating technical insight calculations to ensure an optimal design. Receive design documentation with detailed considerations, material lists, and design specifications.

Proposal and Sales Report

Our sales team will present a comprehensive proposal with the solution and be available to answer any questions.

Pre-installation Support

We provide support to ensure a smooth installation process, including technical training and installation commissioning support.

Post-installation Support

We offer ongoing support, including regular maintenance services to ensure your system runs optimally.

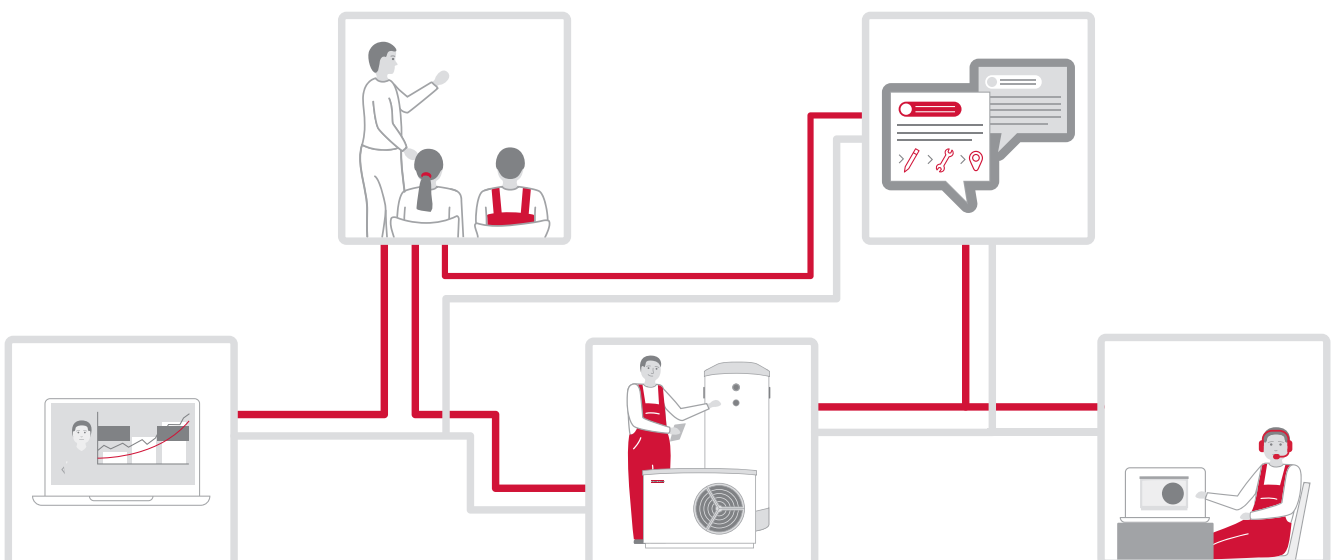

System Overview

Our solutions based on their applicaions

Package Name	CI	CMP	CMT
Application Size	S-M	M-L	M-L
Recovery Rate	8 h	5-7 h	5-7 h
Separate Storage Tanks	No	Yes	Yes
Outdoor Installation	Yes	No	Yes
New Build	Yes	Yes	Yes
Skid Option	No	Yes	Yes
BMS through STE	No	Yes	Yes

Package Naming Conventions

To understand package naming conventions, this table displays the meaning behind each character in each package title.

Example

C X X - X X

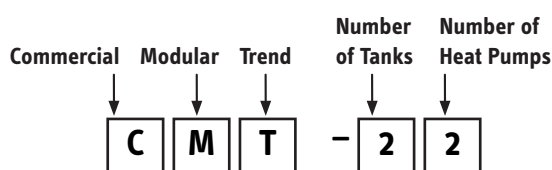

C	Commercial For commercial applications.	P	Premium Indoor installation. Premium STIEBEL ELTRON SBB hot water tanks.
I	Integrated Utilises our all-in-one WWK hot water heat pumps for layout flexibility and quick installation.	#	Number of Heat Pumps Number of heat pumps used in the solution.
M	Modular Utilises our WPL-A 07 air to water heat pumps and separate domestic hot water tanks for a mono-block solution for best capacity to delivery ratio. Medium to large applications.	#	Number of Tanks Numer of hot water tanks used in the solution.
T	Trend Indoor/outdoor installation. Standard hot water tanks.		

Features and Benefits

Lorem ipsum odor amet, consectetur adipiscing elit. Fringilla nostra ad lacinia nullam in non odio tempor facilisis. Leo dui id cras aptent volutpat hendrerit. Quisque litora aptent, nulla mi maecenas nunc habitasse. Pretium urna cras rutrum himenaeos rhoncus. Sodales curae dapibus ante penatibus convallis pulvinar luctus. Eu consectetur felis ultrices lobortis mi vel. blandit nullam varius fusce dignissim nascetur natoque.



Robust Quality

Built to withstand the harshest conditions, our high-quality machines meet all hot water temperature requirements and come pre-tested for maximum reliability.



Highest Efficiency

Delivers up to 75°C flow temperature, ensuring maximum mixing water volumes without the need for additional electric heaters with highest performance factors.



Flexible Installation Options

Installable indoor, outdoor or on a Skid: Available for both on-site installation or pre-manufactured on a skid, providing convenience and adaptability to different project needs.



Easy Installation and Sizing

Pre-matched packs tailored for most apartment sizes, featuring compact, easy-to-allocate components, making installation straightforward.



Solar PV and EMS Integration

Seamlessly integrates with Solar PV and EMS systems to maximise self-consumption or incorporate into a larger energy management system.

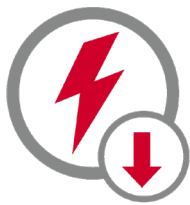

Low Connected Load

Demand for electricity on the grid is low because the products are energy efficient and climate smart, reducing the demand for electricity during peak usage times.

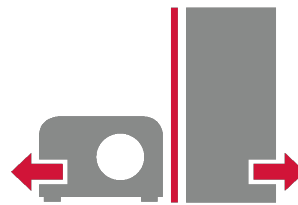

Small manageable components for retrofit or Service

Individual components means that units can be serviced and replaced seperately and in a modular fashion.

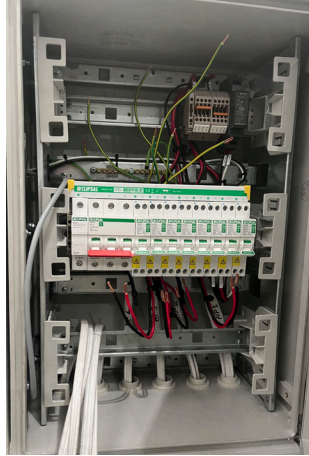

Commercial Integrated

CI

The Commercial Integrated (CI) heat pump packages provide an efficient and dependable solution for small to medium hot water demands in multi-residential and commercial buildings. These systems feature the durable WWK 302 heat pumps, which are engineered for Australian conditions and deliver high-performance hot water heating with minimal environmental impact. By directly heating potable water, the system eliminates the need for plumbing components like heat exchangers or circulation pumps, ensuring a straightforward installation process.

With pre-configured hot water settings, the system is ready to operate immediately upon connection, meeting compliance requirements effortlessly. Its modular design allows for seamless scalability, making it easy to adjust capacity as needs evolve. Maintenance is simplified, with the integrated design enabling swift servicing and reducing potential downtime.

Features and Benefits



Robust Quality

Built to withstand the harshest conditions, our quality machines meet all hot water temperature requirements and come pre-tested for maximum reliability.



Customisability

hot water plant can be expanded or reduced in capacity post-installation with minimal alterations to plumbing or settings



Pre-set hot water parameters

The heat pump comes with saved settings and operates to code compliance once connected to power, eliminating any software input need.



Serviceability

Designed with simplicity in mind, the integrated solution allows for fast fault detection and quick fixes, ensuring minimal downtime.



Direct potable water

No heat exchangers or circulation pumps are required, only simple hot water plumbing in and out of the heat pump.



Incentives

STCs, VEECS, government rebates

Specifications

Package Name	HP Type	QTY	Tanks	Heating Cylinder Volume (L)	Booster Volume (L)	Min. Spatial Requirement (m2)	Dry Weight (kg)	Wet Weight (kg)	Connected Load (A)	Peak Draw (kW)
CI-301	WWK 302	3		810	315	6.53	480.00	1711.00	26.90	6.30
CI-401	WWK 302	4		1080	315	8.52	615.00	2148.00	29.20	6.80
CI-501	WWK 302	5		1350	315	10.51	750.00	2585.00	31.50	7.30
CI-601	WWK 302	6		1620	315	12.50	885.00	3022.00	33.80	7.80
CI-701	WWK 302	7		1890	315	14.49	1020.00	3459.00	36.10	8.30
CI-801	WWK 302	8		2160	315	16.48	1155.00	3896.00	38.40	8.80
CI-901	WWK 302	9		2430	315	18.47	1290.00	4333.00	40.70	9.30
CI-1001	WWK 302	10		2700	315	20.46	1425.00	4770.00	43.00	9.80

Package Overview

Package Sizing Overview (Based on two bedroom apartments)

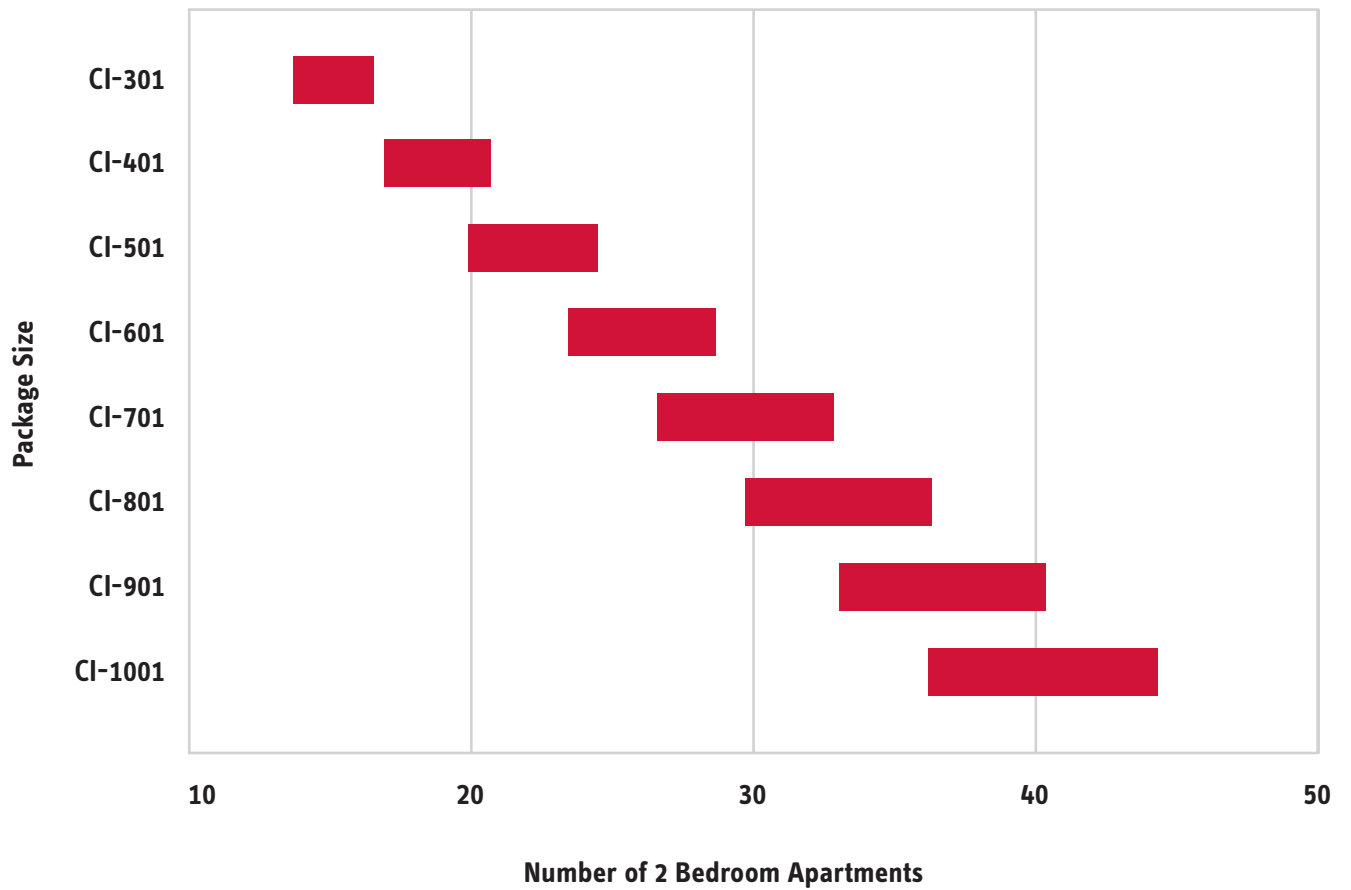

Installation



CI-301

Commercial Integrated 301

Specification wording

The hot water heat pump system shall be a STIEBEL ELTRON CI-301 Commercial Integrated Package, consisting of integrated WWK 302L heat pump units and a 315L reticulation booster tank. The system will include 3 STIEBEL ELTRON WWK 302L units, each capable of direct potable water heating. The units shall be designed for high efficiency with a superior Coefficient of Performance (COP) and come pre-configured to comply with Australian Standards. Constructed with durable materials, they are suitable for installation in outdoor environments.

The electric reticulation tank will have a 315L capacity with a 4.8 kW heating element and 50mm inlet, outlet, and return ports. It will be plumbed in line with the heat pump units, with the ring main return connected to the lowest port to ensure consistent temperature regulation.

It must comply with xxx standards and be eligible for government or state incentives where applicable.

Package Name	CI-301
HP Type	WWK 302
QTY	3
Heating Cylinder Volume (L)	810
Booster Volume (L)	315
Min. Spatial Requirement (m2)	6.53
Dry Weight (kg)	480.00
Wet Weight (kg)	1711.00
Connected load (A)	26.90
Peak Draw (kW)	6.30

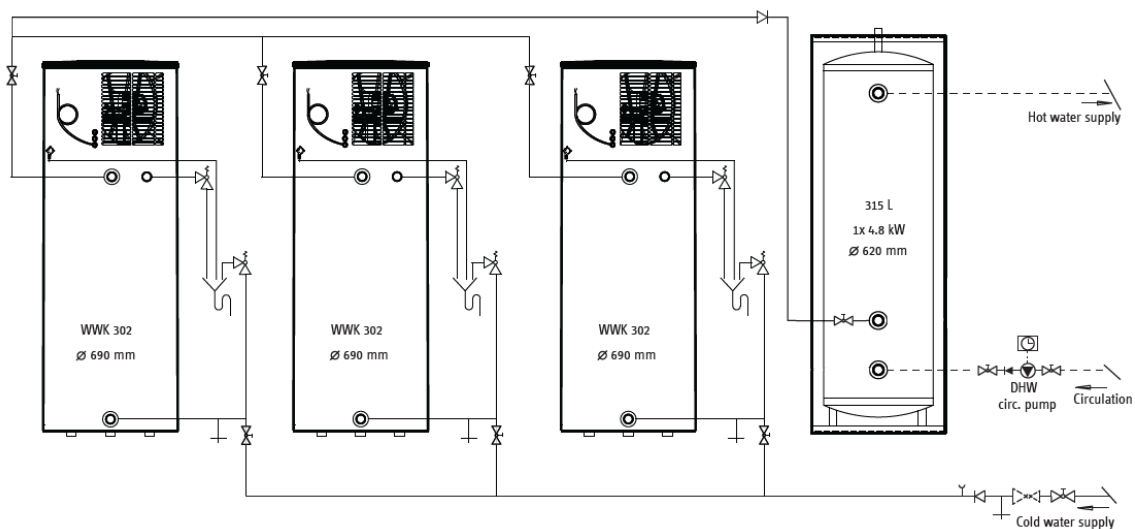

CI-401

Commercial Integrated 401

Specification wording

The hot water heat pump system shall be a STIEBEL ELTRON CI-401 Commercial Integrated Package, consisting of integrated WWK 302L heat pump units and a 315L reticulation booster tank. The system will include 4 STIEBEL ELTRON WWK 302L units, each capable of direct potable water heating. The units shall be designed for high efficiency with a superior Coefficient of Performance (COP) and come pre-configured to comply with Australian Standards. Constructed with durable materials, they are suitable for installation in outdoor environments.

The electric reticulation tank will have a 315L capacity with a 4.8 kW heating element and 50mm inlet, outlet, and return ports. It will be plumbed in line with the heat pump units, with the ring main return connected to the lowest port to ensure consistent temperature regulation.

It must comply with xxx standards and be eligible for government or state incentives where applicable.

Package Name	CI-401
HP Type	WWK 302
QTY	4
Heating Cylinder Volume (L)	1080
Booster Volume (L)	315
Min. Spatial Requirement (m2)	8.52
Dry Weight (kg)	615.00
Wet Weight (kg)	2148.00
Connected load (A)	29.20
Peak Draw (kW)	6.80

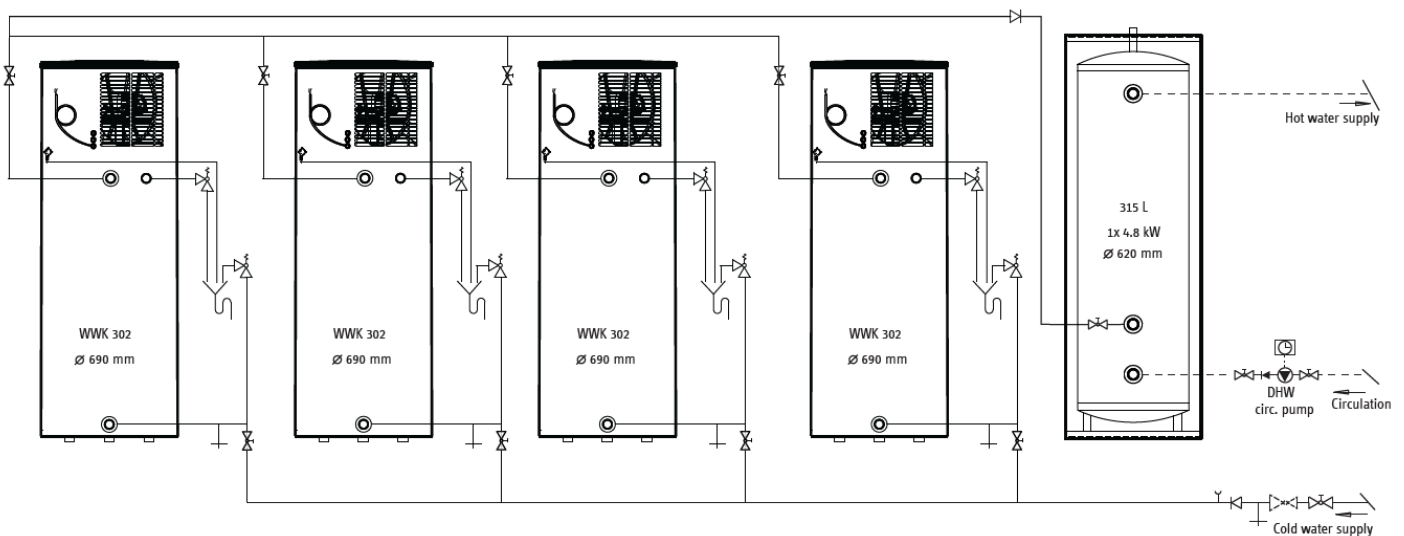

CI-501

Commercial Integrated 501

Specification wording

The hot water heat pump system shall be a STIEBEL ELTRON CI-501 Commercial Integrated Package, consisting of integrated WWK 302L heat pump units and a 315L reticulation booster tank. The system will include 5 STIEBEL ELTRON WWK 302L units, each capable of direct potable water heating. The units shall be designed for high efficiency with a superior Coefficient of Performance (COP) and come pre-configured to comply with Australian Standards. Constructed with durable materials, they are suitable for installation in outdoor environments.

The electric reticulation tank will have a 315L capacity with a 4.8 kW heating element and 50mm inlet, outlet, and return ports. It will be plumbed in line with the heat pump units, with the ring main return connected to the lowest port to ensure consistent temperature regulation.

It must comply with xxx standards and be eligible for government or state incentives where applicable.

Package Name	CI-501
HP Type	WWK 302
QTY	5
Heating Cylinder Volume (L)	1350
Booster Volume (L)	315
Min. Spatial Requirement (m2)	10.51
Dry Weight (kg)	750.00
Wet Weight (kg)	2585.00
Connected load (A)	31.50
Peak Draw (kW)	7.30

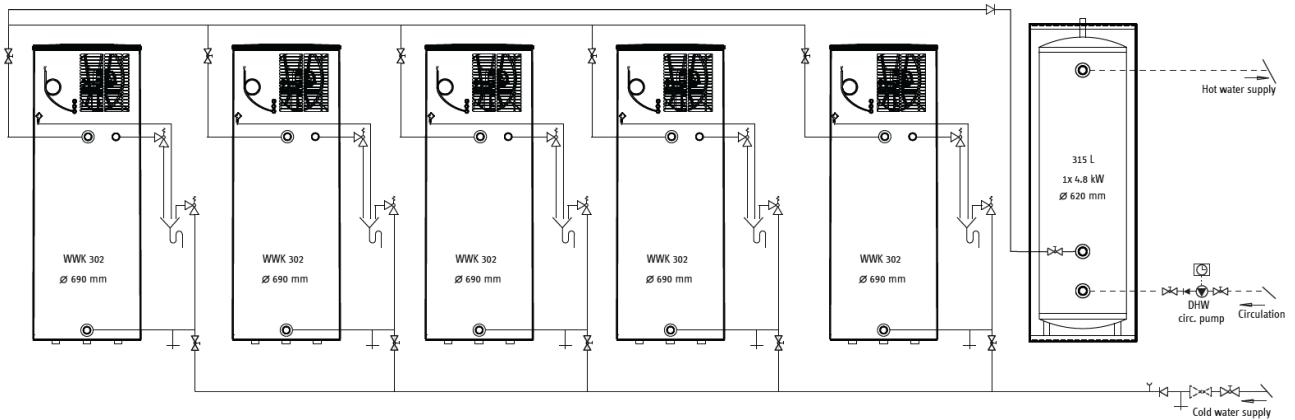

CI-601

Commercial Integrated 601

Specification wording

The hot water heat pump system shall be a STIEBEL ELTRON CI-601 Commercial Integrated Package, consisting of integrated WWK 302L heat pump units and a 315L reticulation booster tank. The system will include 6 STIEBEL ELTRON WWK 302L units, each capable of direct potable water heating. The units shall be designed for high efficiency with a superior Coefficient of Performance (COP) and come pre-configured to comply with Australian Standards. Constructed with durable materials, they are suitable for installation in outdoor environments.

The electric reticulation tank will have a 315L capacity with a 4.8 kW heating element and 50mm inlet, outlet, and return ports. It will be plumbed in line with the heat pump units, with the ring main return connected to the lowest port to ensure consistent temperature regulation.

It must comply with xxx standards and be eligible for government or state incentives where applicable.

Package Name	CI-601
HP Type	WWK 302
QTY	6
Heating Cylinder Volume (L)	1620
Booster Volume (L)	315
Min. Spatial Requirement (m2)	12.50
Dry Weight (kg)	885.00
Wet Weight (kg)	3022.00
Connected load (A)	33.80
Peak Draw (kW)	7.80

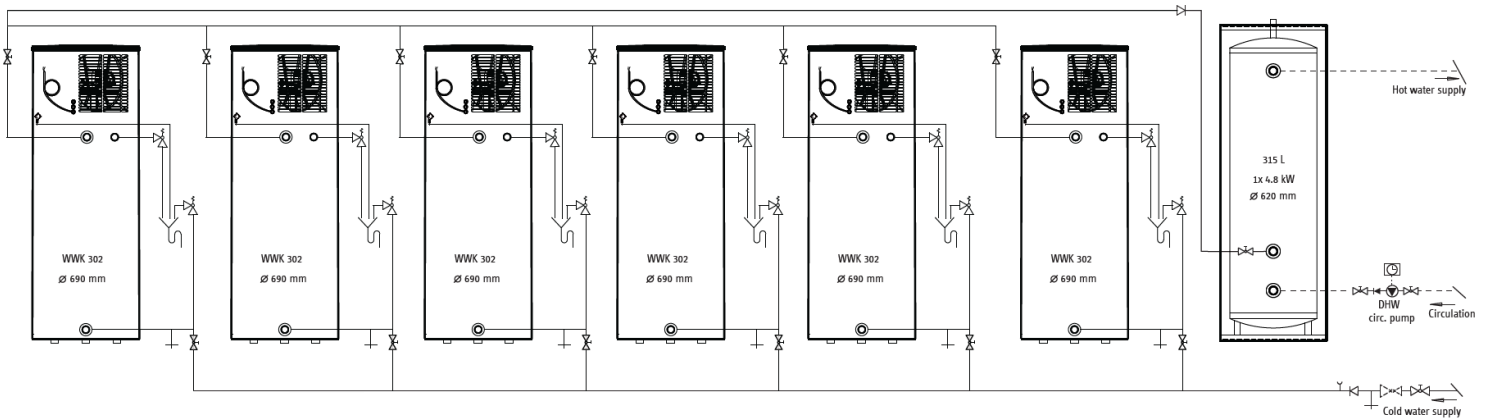

CI-701

Commercial Integrated 701

Specification wording

The hot water heat pump system shall be a STIEBEL ELTRON CI-701 Commercial Integrated Package, consisting of integrated WWK 302L heat pump units and a 315L reticulation booster tank. The system will include 7 STIEBEL ELTRON WWK 302L units, each capable of direct potable water heating. The units shall be designed for high efficiency with a superior Coefficient of Performance (COP) and come pre-configured to comply with Australian Standards. Constructed with durable materials, they are suitable for installation in outdoor environments.

The electric reticulation tank will have a 315L capacity with a 4.8 kW heating element and 50mm inlet, outlet, and return ports. It will be plumbed in line with the heat pump units, with the ring main return connected to the lowest port to ensure consistent temperature regulation.

It must comply with xxx standards and be eligible for government or state incentives where applicable.

Package Name	CI-701
HP Type	WWK 302
QTY	7
Heating Cylinder Volume (L)	1890
Booster Volume (L)	315
Min. Spatial Requirement (m2)	14.49
Dry Weight (kg)	1020.00
Wet Weight (kg)	3459.00
Connected load (A)	36.10
Peak Draw (kW)	8.30

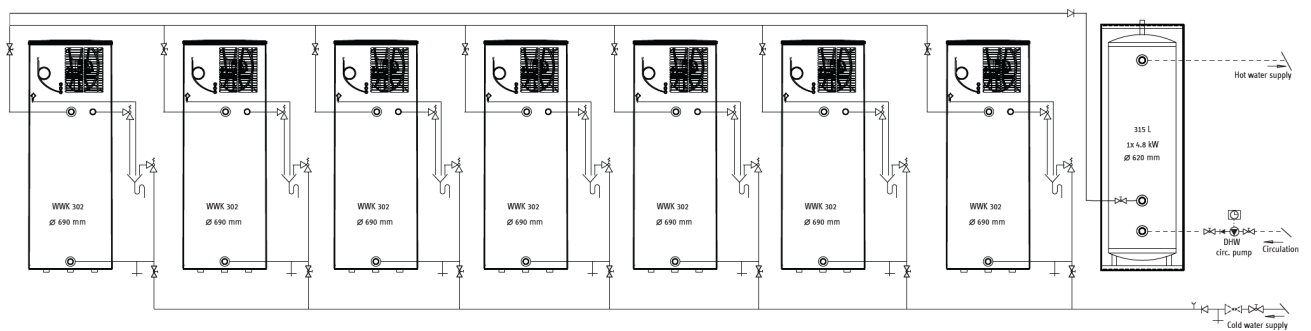

CI-801

Commercial Integrated 801

Specification wording

The hot water heat pump system shall be a STIEBEL ELTRON CI-801 Commercial Integrated Package, consisting of integrated WWK 302L heat pump units and a 315L reticulation booster tank. The system will include 8 STIEBEL ELTRON WWK 302L units, each capable of direct potable water heating. The units shall be designed for high efficiency with a superior Coefficient of Performance (COP) and come pre-configured to comply with Australian Standards. Constructed with durable materials, they are suitable for installation in outdoor environments.

The electric reticulation tank will have a 315L capacity with a 4.8 kW heating element and 50mm inlet, outlet, and return ports. It will be plumbed in line with the heat pump units, with the ring main return connected to the lowest port to ensure consistent temperature regulation.

It must comply with xxx standards and be eligible for government or state incentives where applicable.

Package Name	CI-801
HP Type	WWK 302
QTY	8
Heating Cylinder Volume (L)	2160
Booster Volume (L)	315
Min. Spatial Requirement (m2)	16.48
Dry Weight (kg)	1155.00
Wet Weight (kg)	3896.00
Connected load (A)	38.40
Peak Draw (kW)	8.80

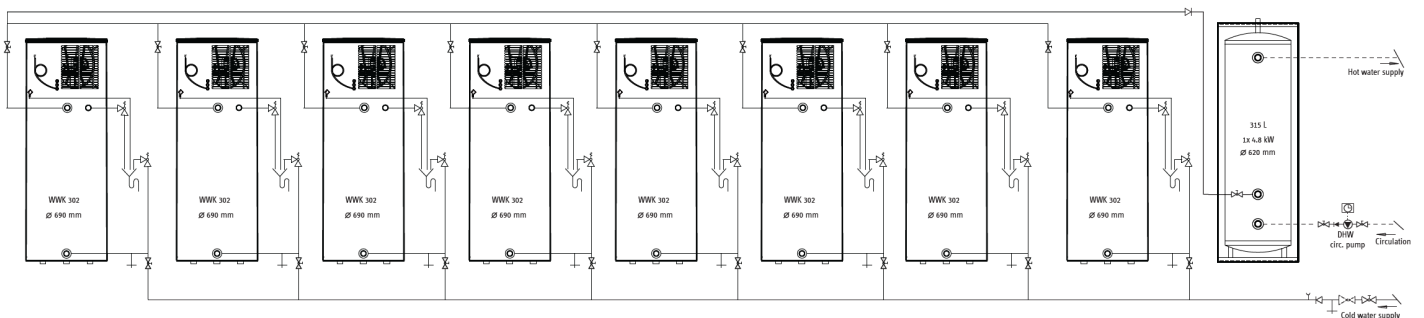

CI-901

Commercial Integrated 901

Specification wording

The hot water heat pump system shall be a STIEBEL ELTRON CI-901 Commercial Integrated Package, consisting of integrated WWK 302L heat pump units and a 315L reticulation booster tank. The system will include 9 STIEBEL ELTRON WWK 302L units, each capable of direct potable water heating. The units shall be designed for high efficiency with a superior Coefficient of Performance (COP) and come pre-configured to comply with Australian Standards. Constructed with durable materials, they are suitable for installation in outdoor environments.

The electric reticulation tank will have a 315L capacity with a 4.8 kW heating element and 50mm inlet, outlet, and return ports. It will be plumbed in line with the heat pump units, with the ring main return connected to the lowest port to ensure consistent temperature regulation.

It must comply with xxx standards and be eligible for government or state incentives where applicable.

Package Name	CI-901
HP Type	WWK 302
QTY	9
Heating Cylinder Volume (L)	2430
Booster Volume (L)	315
Min. Spatial Requirement (m2)	18.47
Dry Weight (kg)	1290.00
Wet Weight (kg)	4333.00
Connected load (A)	40.70
Peak Draw (kW)	9.30

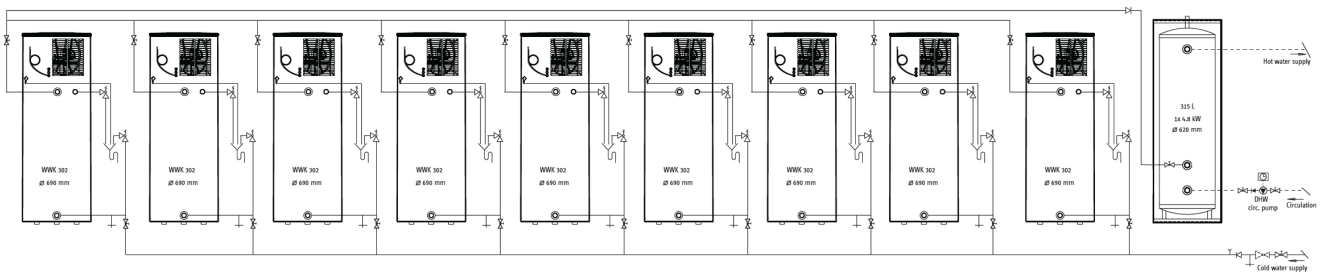

CI-1001

Commercial Integrated 1001

Specification wording

The hot water heat pump system shall be a STIEBEL ELTRON CI-1001 Commercial Integrated Package, consisting of integrated WWK 302L heat pump units and a 315L reticulation booster tank. The system will include 10 STIEBEL ELTRON WWK 302L units, each capable of direct potable water heating. The units shall be designed for high efficiency with a superior Coefficient of Performance (COP) and come pre-configured to comply with Australian Standards. Constructed with durable materials, they are suitable for installation in outdoor environments.

The electric reticulation tank will have a 315L capacity with a 4.8 kW heating element and 50mm inlet, outlet, and return ports. It will be plumbed in line with the heat pump units, with the ring main return connected to the lowest port to ensure consistent temperature regulation.

It must comply with xxx standards and be eligible for government or state incentives where applicable.

Package Name	CI-1001
HP Type	WWK 302
QTY	10
Heating Cylinder Volume (L)	2700
Booster Volume (L)	315
Min. Spatial Requirement (m2)	20.46
Dry Weight (kg)	1425.00
Wet Weight (kg)	4770.00
Connected load (A)	43.00
Peak Draw (kW)	9.80

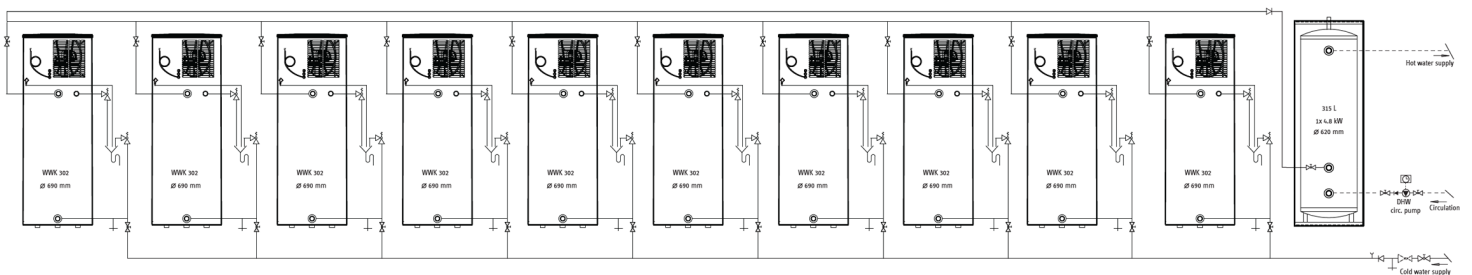

Commercial Modular Trend

CMT

The STIEBEL ELTRON CMT package provides a flexible and scalable hot water solution for medium to large applications, featuring cascaded WPL A07 monobloc air-water heat pumps paired with stainless steel 829L closed-loop storage tanks. Engineered for maximum efficiency, the system incorporates inverter technology to optimize energy use, reduce start-up power, and enable precise recirculation recovery through the tanks, or directly via the heat pump.

The stainless-steel tanks are designed for outdoor use and sized specifically to handle Australia's diverse water conditions, ensuring durability and reliability. The WPL A07 delivers low Global Warming Potential (GWP) performance with high flow temperatures of up to 75°C, maintaining excellent efficiency. Configurable for up to six heat pump and tank pairings, the CMT package ensures robust and adaptable performance for various installation scenarios. Its compliance with Australian Standards makes it ideal for sustainable new builds and retrofits alike.

Features and Benefits

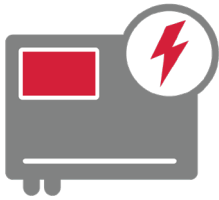

Inverter technology

Provides high energy efficiency, recirculation recovery and less start up power, overall saving on consumption costs.



Stainless Steel tank

For outdoor used design specially for the application in terms of sizing and to meet most water conditions throughout Australia



Included electrical enclosure

Providing environmental protection, security and safety, with all controls, breakers and internet service gateway included.

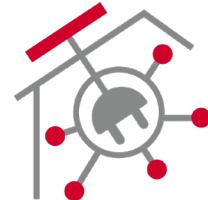

Solar PV and EMS Integration

Seamlessly integrates with Solar PV and EMS systems to maximise self-consumption or incorporate into a larger energy management system.



High flow temperature

High flow temperatures of up to 75°C enable high DHW temperatures and mixed water volumes.

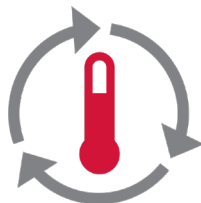

Recirculation recovery

Either through external boosters, through tanks or highest efficiency through heat pumps



Low GWP

A low GWP refrigerant is a safe and sustainable option with a lower climate impact.



Remote Access

Convenient settings and analysis from the back office or through BMS integration saves time and provides all necessary information.

Specifications

Package Name	HP Type	QTY	Tanks	Heating Cylinder Volume (L)	Min. Spatial Requirement (m2)	Dry Weight (kg)	Wet Weight (kg)	Connected Load (A)	Peak Draw (kW)	Electrical box sub main
CM-T 11	WPL-A 07	1	1	829	5	287.00	1116.00	50.00	11.70	20A/PH 415V
CM-T 22	WPL-A 07	2	2	1658	9	574.00	2232.00	90.00	23.40	32A/PH 415V
CM-T 33	WPL-A 07	3	3	2487	13	861.00	3348.00	130.00	35.10	40A/PH 415V
CM-T 44	WPL-A 07	4	4	3316	17	1148.00	4464.00	170.00	46.80	63A/PH 415V
CM-T 55	WPL-A 07	5	5	4145	22	1435.00	5580.00	210.00	58.50	80A/PH 415V
CM-T 66	WPL-A 07	6	6	4974	26	1722.00	6696.00	250.00	70.20	100A/PH 415V

Package Overview

Package Sizing Overview (Based on two bedroom apartments)



Installation



Prefabricated Skid Overview

Prefabricated Options

In addition to free installation layout using our modular components, STIEBEL ELTRON offers two prefabricated skid system variants designed to accelerate deployment, ensure build quality, and maintain flexibility to meet the specific needs of your project. Both options reduce on-site time, costs, and risks, while delivering consistency and high-quality execution.



Prefabricated Skid



Save time, provide a fast and reliable install, and avoid ambient risk factors with a product that has been pretested in the factory.

Full Skid

This turnkey solution includes a complete heat pump and tank assembly mounted on a structural steel skid. All hydraulic and potable water connections, electrical wiring, insulation, and commissioning checks are completed at the factory. The system is pre-tested, pressure tested and supplied with insulation and a crane lifting certificate. This package is ideal for projects requiring fast, hassle-free installation with minimal site coordination or trades.

Combi Skid

The combi skid solution separates the plant into heat pump modules and 2- or 3-pack tank modules. Each module is preassembled, insulated, and pressure tested, ready for craning directly to site. The potable and hydronic circuits are fully integrated on the skid. Electrical installation is the only on-site task and is supported by a prewired control enclosure with all necessary breakers, controls, and an Internet Service Gateway. Each module connects via minimum 500mm pipes, enabling fast and flexible deployment with minimal on-site work and reduced commissioning complexity.

	Heat Pumps and Tanks	Controls, Display, BMS	Servicewelt Access	Mechanical Accessories	Electrical Enclosure	Pressure Tested	Mechanical Plumbing	Insulation	Craning, Seismic and Windload Calculations	Electrical Installation	Potable Plumbing	PTR Drainage
 Full Skid	●	●	●	●	●	●	●	●	●	●	○	○
 Combi Skid	●	●	●	●	●	●	●	●	●	●	○	○
 Flex	●	●	●	●	●	○	○	○	○	○	○	○

Key

- Standard Delivery
- ◐ Onsite Finish
- Optional

Specification - Full Skid System

The hot water plant shall be supplied as a full skid-mounted system. All hydraulic and potable water pipework, insulation, and electrical connections shall be factory-installed, pressure tested, and pre-commissioned. The system shall include all necessary thermal insulation, crane lifting points, and certification for transport and rooftop installation. The skid shall be delivered as a plug-and-play solution requiring only connection of mains power, cold water inlet, hot water outlet, and ring main return.

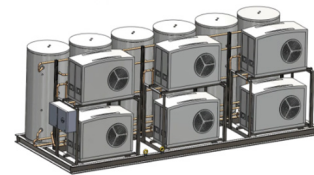
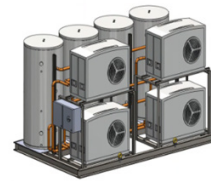
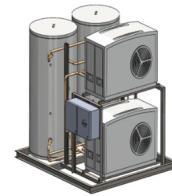

Pack:	2-2	3-3	4-4	5-5	6-6
Width (mm)	2400	2400	2400	2400	2400
Length (mm)	2050	4000	4000	6000	6000
Height (mm)	2241	2291	2291	2291	2291
Dry Weight approx (kg)	900	1583	1937	2558	2905
Wet Weight approx (kg)	2648	4241	5436	6941	8130

Specification - Combi Skid System

The hot water plant shall be delivered as a combi skid system, comprising separate heat pump and tank assemblies. Each skid module shall be factory-built, pressure tested, fully insulated, and ready for craning. Hydraulic and potable connections shall be preinstalled. Electrical connection shall be performed on-site via a supplied prewired control enclosure including breakers, controls, and Internet Service Gateway. Each module shall feature 2 connections for the hydraulics and 3 for the potable pipes to facilitate rapid on-site integration and scalable system layout.



	2 Pack Heat Pumps	5 Pack Heat Pumps no tanks	6 Pack Heat Pumps no tanks	2 Tank	3 Tank
Width (mm)	1400	1400	1400	1400	1400
Length (mm)	2050	6000	6000	2050	3000
Height (mm)	2291	2291	2291	2120	2120
Dry Weight approx (kg)	550	1740	1740	670	950
Wet Weight approx (kg)	•	•	•	2322	3428

CMT-11

Commercial Modular Trend 11

Specification wording

The hot water plant shall be a closed-loop heat pump system meeting the following requirements:

The system shall consist of one (1) WPL-A 07 air-to-water monobloc outdoor heat pump units, each coupled to one (1) 829L nominal domestic hot water (DHW) coil tanks, with a total stored water volume of 829L. The system shall provide a heating output of 8kW at 5°C ambient air temperature with water temperatures up to 65°C directly from the tanks, without reliance on additional electric boosting. The heat pumps shall be capable of achieving flow temperatures up to 75°C and operate on R454C, a low Global Warming Potential (GWP) refrigerant. The installation can be done internal or external.

The heat pumps shall operate in a true cascade, managed by a centralised Heat Pump Manager to ensure uniform machine scheduling and optimal efficiency. The system shall be equipped with an Internet Service Gateway connected to the Heat Pump Manager and a network router/switch to enable remote service visibility and building management system (BMS) integration via MODBUS protocol.

The system shall require a connected load of 50A at 230VAC, be WaterMark certified, and be suitable for outdoor installation. Each installation shall include a 20A/PH 415V central control panel for manual selection and monitoring tank temperature, ambient air temperature, and system performance metrics. The system shall comply with all relevant Australian Standards and be configured for long-term efficiency and reliability.

Package Name	CMT-11
HP Type	WPL A-07
QTY	1
Tanks	1
Heating Cylinder Volume (L)	829
Min. Spatial Requirement (m2)	4.23
Dry Weight (kg)	287.00
Wet Weight (kg)	1116.00
Connected load (A)	50.00
Peak Draw (kW)	11.70
Electrical Box Sub Main (V)	20A/PH 415V

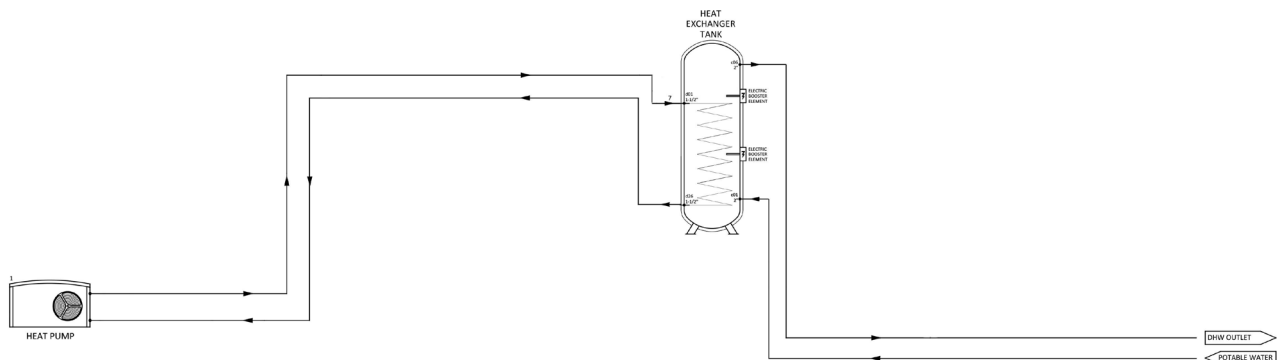

CMT-22

CMT-22

Specification wording

The hot water plant shall be a closed-loop heat pump system meeting the following requirements:

The system shall consist of two (2) WPL-A 07 air-to-water monobloc outdoor heat pump units, each coupled to two (2) 829L nominal domestic hot water (DHW) coil tanks, with a total stored water volume of 1658L. The system shall provide a heating output of 16 kW at 5°C ambient air temperature with water temperatures up to 65°C directly from the tanks, without reliance on additional electric boosting. The heat pumps shall be capable of achieving flow temperatures up to 75°C and operate on R454C, a low Global Warming Potential (GWP) refrigerant. The installation can be done internal or external.

The heat pumps shall operate in a true cascade, managed by a centralised Heat Pump Manager to ensure uniform machine scheduling and optimal efficiency. The system shall be equipped with an Internet Service Gateway connected to the Heat Pump Manager and a network router/switch to enable remote service visibility and building management system (BMS) integration via MODBUS protocol.

The system shall require a connected load of 90A at 230VAC, be WaterMark certified, and be suitable for outdoor installation. Each installation shall include a 32A/PH 415V central control panel for manual selection and monitoring tank temperature, ambient air temperature, and system performance metrics. The system shall comply with all relevant Australian Standards and be configured for long-term efficiency and reliability.

Package Name	CMT-22
HP Type	WPL A-07
QTY	2
Tanks	2
Heating Cylinder Volume (L)	1658
Min. Spatial Requirement (m2)	8.46
Dry Weight (kg)	574.00
Wet Weight (kg)	2232.00
Connected load (A)	90.00
Peak Draw (kW)	23.40
Electrical Box Sub Main (V)	32A/PH 415V

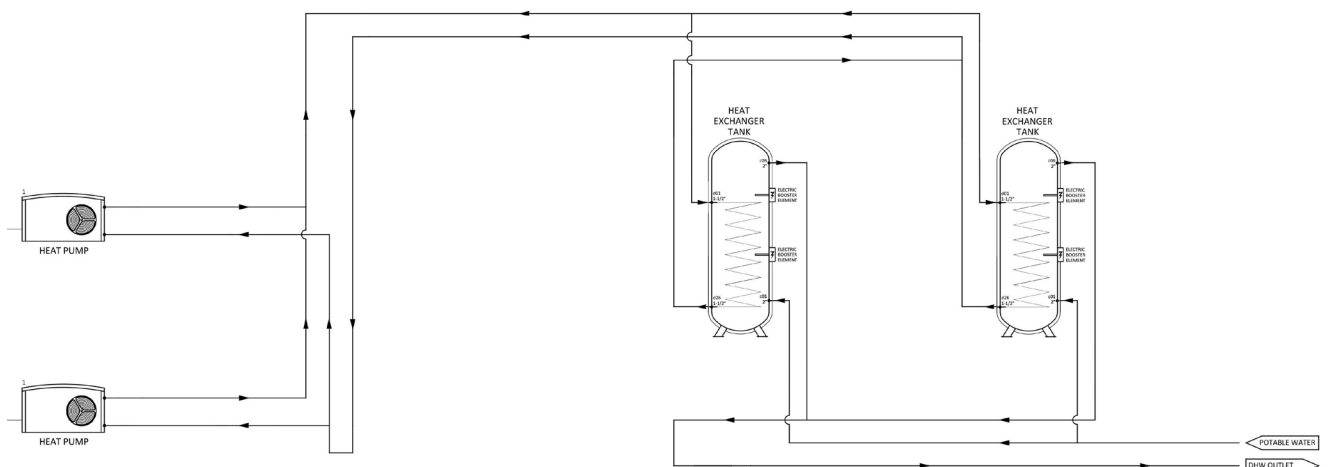

CMT-33

Commercial Modular Trend 33

Specification wording

The hot water plant shall be a closed-loop heat pump system meeting the following requirements:

The system shall consist of three (3) WPL-A 07 air-to-water monobloc outdoor heat pump units, each coupled to three (3) 829L nominal domestic hot water (DHW) coil tanks, with a total stored water volume of 2487L. The system shall provide a heating output of 24kW at 5°C ambient air temperature with water temperatures up to 65°C directly from the tanks, without reliance on additional electric boosting. The heat pumps shall be capable of achieving flow temperatures up to 75°C and operate on R454C, a low Global Warming Potential (GWP) refrigerant. The installation can be done internal or external.

The heat pumps shall operate in a true cascade, managed by a centralised Heat Pump Manager to ensure uniform machine scheduling and optimal efficiency. The system shall be equipped with an Internet Service Gateway connected to the Heat Pump Manager and a network router/switch to enable remote service visibility and building management system (BMS) integration via MODBUS protocol.

The system shall require a connected load of 130A at 230VAC, be WaterMark certified, and be suitable for outdoor installation. Each installation shall include a 40A/PH 415V central control panel for manual selection and monitoring tank temperature, ambient air temperature, and system performance metrics. The system shall comply with all relevant Australian Standards and be configured for long-term efficiency and reliability.

Package Name	CMT-33
HP Type	WPL A-07
QTY	3
Tanks	3
Heating Cylinder Volume (L)	2487
Min. Spatial Requirement (m2)	12.69
Dry Weight (kg)	861.00
Wet Weight (kg)	3348.00
Connected load (A)	130.00
Peak Draw (kW)	35.10
Electrical Box Sub Main (V)	40A/PH 415V

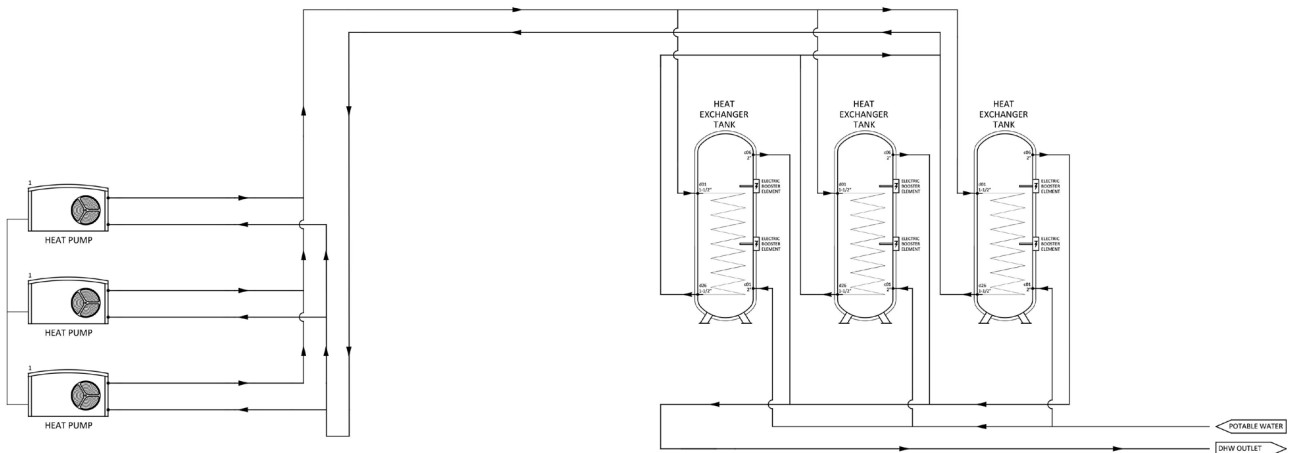

CMT-44

Commercial Modular Trend 44

Specification wording

The hot water plant shall be a closed-loop heat pump system meeting the following requirements:

The system shall consist of four (4) WPL-A 07 air-to-water monobloc outdoor heat pump units, each coupled to four (4) 829L nominal domestic hot water (DHW) coil tanks, with a total stored water volume of 3316L. The system shall provide a heating output of 36 kW at 5°C ambient air temperature with water temperatures up to 65°C directly from the tanks, without reliance on additional electric boosting. The heat pumps shall be capable of achieving flow temperatures up to 75°C and operate on R454C, a low Global Warming Potential (GWP) refrigerant. The installation can be done internal or external.

The heat pumps shall operate in a true cascade, managed by a centralised Heat Pump Manager to ensure uniform machine scheduling and optimal efficiency. The system shall be equipped with an Internet Service Gateway connected to the Heat Pump Manager and a network router/switch to enable remote service visibility and building management system (BMS) integration via MODBUS protocol.

The system shall require a connected load of 170A at 230VAC, be WaterMark certified, and be suitable for outdoor installation. Each installation shall include a 63A/PH 415V central control panel for manual selection and monitoring tank temperature, ambient air temperature, and system performance metrics. The system shall comply with all relevant Australian Standards and be configured for long-term efficiency and reliability.

Package Name	CMT-44
HP Type	WPL A-07
QTY	4
Tanks	4
Heating Cylinder Volume (L)	3316
Min. Spatial Requirement (m2)	16.92
Dry Weight (kg)	1148.00
Wet Weight (kg)	4464.00
Connected load (A)	170.00
Peak Draw (kW)	46.80
Electrical Box Sub Main (V)	63A/PH 415V

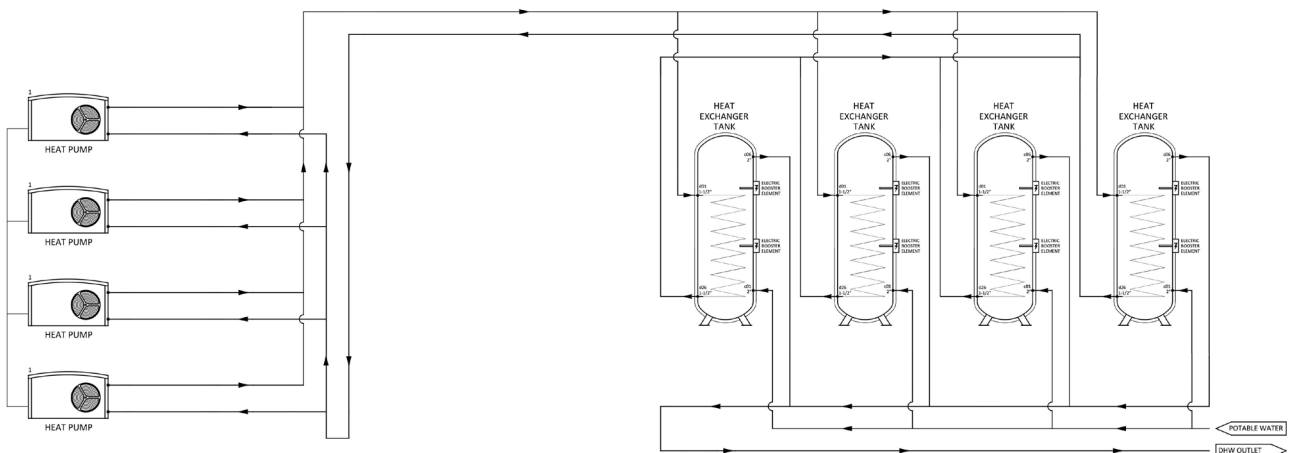

CMT-55

Commercial Modular Trend 55

Specification wording

The hot water plant shall be a closed-loop heat pump system meeting the following requirements:

The system shall consist of five (5) WPL-A 07 air-to-water monobloc outdoor heat pump units, each coupled to five (5) 829L nominal domestic hot water (DHW) coil tanks, with a total stored water volume of 4,145L. The system shall provide a heating output of 40 kW at 5°C ambient air temperature with water temperatures up to 65°C directly from the tanks, without reliance on additional electric boosting. The heat pumps shall be capable of achieving flow temperatures up to 75°C and operate on R454C, a low Global Warming Potential (GWP) refrigerant. The installation can be done internal or external.

The heat pumps shall operate in a true cascade, managed by a centralised Heat Pump Manager to ensure uniform machine scheduling and optimal efficiency. The system shall be equipped with an Internet Service Gateway connected to the Heat Pump Manager and a network router/switch to enable remote service visibility and building management system (BMS) integration via MODBUS protocol.

The system shall require a connected load of 210A at 230VAC, be WaterMark certified, and be suitable for outdoor installation. Each installation shall include a 80A/PH 415V central control panel for manual selection and monitoring tank temperature, ambient air temperature, and system performance metrics. The system shall comply with all relevant Australian Standards and be configured for long-term efficiency and reliability.

Package Name	CMT-55
HP Type	WPL A-07
QTY	5
Tanks	5
Heating Cylinder Volume (L)	4145
Min. Spatial Requirement (m2)	21.15
Dry Weight (kg)	1435.00
Wet Weight (kg)	5580.00
Connected load (A)	210.00
Peak Draw (kW)	58.50
Electrical Box Sub Main (V)	80A/PH 415V

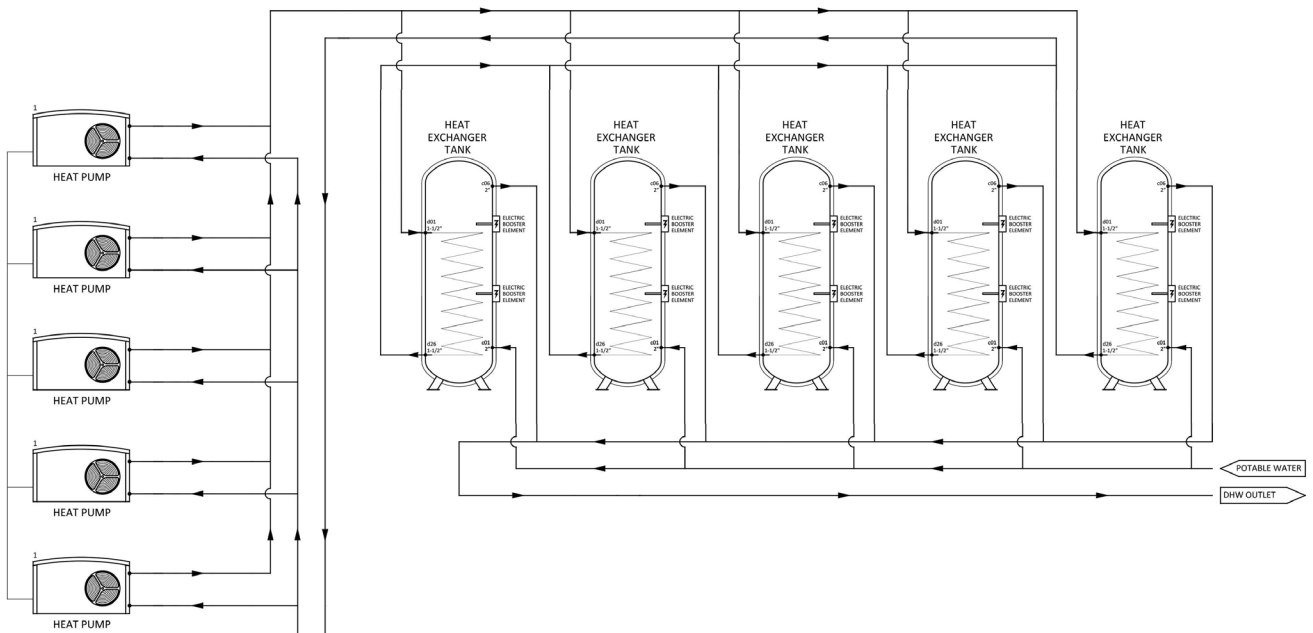

CMT-66

Commercial Modular Trend 66

Specification wording

The hot water plant shall be a closed-loop heat pump system meeting the following requirements:

The system shall consist of six (6) WPL-A 07 air-to-water monobloc outdoor heat pump units, each coupled to six (6) 829L nominal domestic hot water (DHW) coil tanks, with a total stored water volume of 4974L. The system shall provide a heating output of 48 kW at 5°C ambient air temperature with water temperatures up to 65°C directly from the tanks, without reliance on additional electric boosting. The heat pumps shall be capable of achieving flow temperatures up to 75°C and operate on R454C, a low Global Warming Potential (GWP) refrigerant. The installation can be done internal or external.

The heat pumps shall operate in a true cascade, managed by a centralised Heat Pump Manager to ensure uniform machine scheduling and optimal efficiency. The system shall be equipped with an Internet Service Gateway connected to the Heat Pump Manager and a network router/switch to enable remote service visibility and building management system (BMS) integration via MODBUS protocol.

The system shall require a connected load of 250A at 230VAC, be WaterMark certified, and be suitable for outdoor installation. Each installation shall include a 100A/PH 415V central control panel for manual selection and monitoring tank temperature, ambient air temperature, and system performance metrics. The system shall comply with all relevant Australian Standards and be configured for long-term efficiency and reliability.

Package Name	CMT-66
HP Type	WPL A-07
QTY	6
Tanks	6
Heating Cylinder Volume (L)	4974
Min. Spatial Requirement (m2)	25.38
Dry Weight (kg)	1722.00
Wet Weight (kg)	6696.00
Connected load (A)	250.00
Electrical Box Sub Main (V)	100A/PH 415V

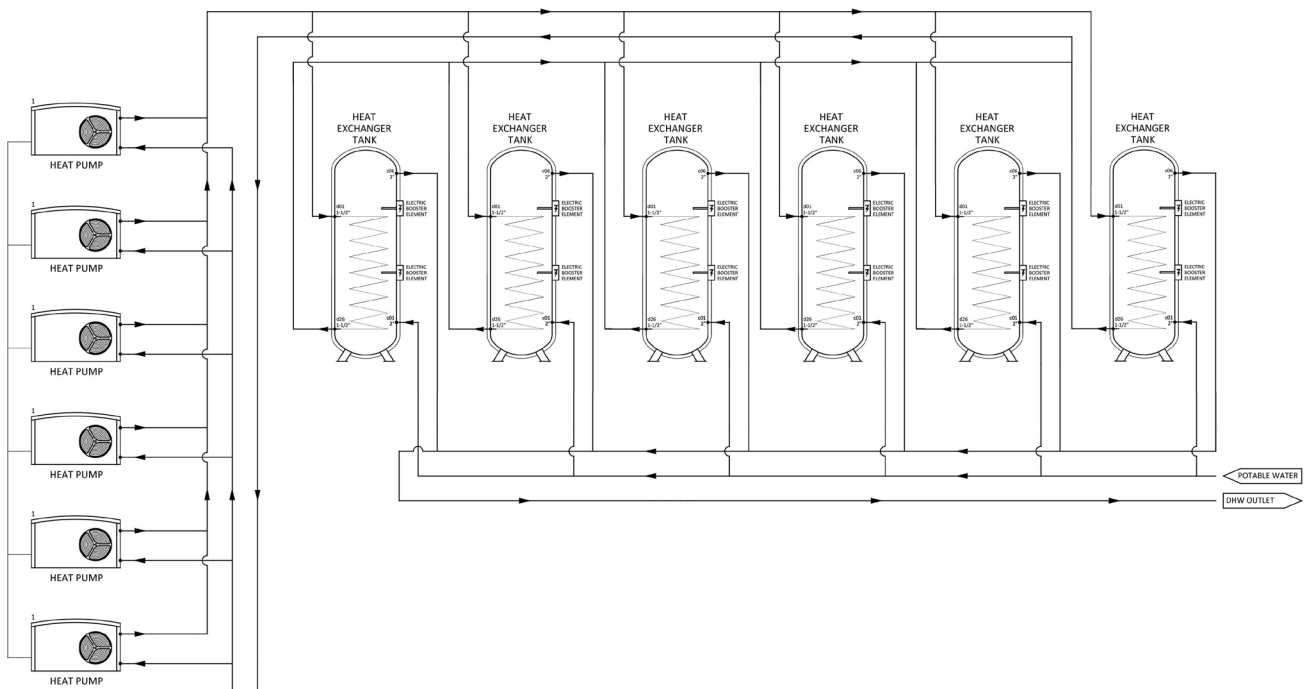

Commercial Modular Premium

CMP

The STIEBEL ELTRON CMP package delivers a premium hot water solution for medium to large indoor applications, particularly suited for challenging retrofit scenarios. This system features cascaded WPL A07 monobloc air-water heat pumps paired with ultra-efficient enamel steel tanks, which include high-performance insulation and removable jackets for installation in narrow plant rooms with limited entry gaps. This makes the CMP package ideal for retrofits or installations in confined spaces.

The system employs inverter technology for maximum efficiency, reduced start-up power, and flexible reticulation recovery options through tanks, or directly via the heat pump for the highest energy savings. Utilizing a low Global Warming Potential (GWP) refrigerant, the WPL A07 delivers flow temperatures of up to 75°C with industry-leading efficiency. The CMP's modular design allows for up to six heat pump and tank combinations, offering scalability and adaptability while ensuring compliance with Australian Standards for sustainable, efficient performance.

Features and Benefits

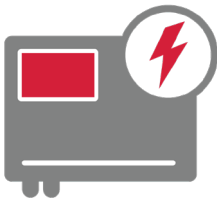

Inverter technology

Provides high energy efficiency, recirculation recovery and less start up power, overall saving on consumption costs.



Stainless Steel tank

For outdoor used design specially for the application in terms of sizing and to meet most water conditions throughout Australia



Included electrical enclosure

Providing environmental protection, security and safety, with all controls, breakers and internet service gateway included.

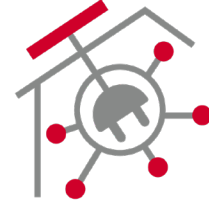

Solar PV and EMS Integration

Seamlessly integrates with Solar PV and EMS systems to maximise self-consumption or incorporate into a larger energy management system.



High flow temperature

High flow temperatures of up to 75°C enable high DHW temperatures and mixed water volumes.



Recirculation recovery

Either through external boosters, through tanks or highest efficiency through heat pumps



Low GWP

A low GWP refrigerant is a safe and sustainable option with a lower climate impact.



Remote Access

Convenient settings and analysis from the back office or through BMS integration saves time and provides all necessary information.

Specifications

Package Name	HP Type	QTY	Tanks	Heating Cylinder Volume (L)	Booster Volume (L)	Min. Spatial Requirement (m2)	Dry Weight (kg)	Wet Weight (kg)	Connected Load (A)	Peak Draw (kW)	Electrical Box Sub Main
CMP-11	WPL A-07	1	1	770	315	5.78	506.00	1674.00	55.00	9.30	20A/PH 415V
CMP-22	WPL A-07	2	2	1540	315	9.02	937.00	2948.00	80.00	13.80	32A/PH 415V
CMP-33	WPL A-07	3	3	2310	315	16.22	1368.00	4222.00	105.00	18.30	40A/PH 415V
CMP-44	WPL A-07	4	4	3080	315	14.92	1799.00	5496.00	170.00	32.40	63A/PH 415V
CMP-55	WPL A-07	5	5	3850	315	19.51	2230.00	6770.00	195.00	36.90	80A/PH 415V
CMP-66	WPL A-07	6	6	4620	315	23.30	2661.00	8044.00	220.00	41.40	80A/PH 415V

Package Overview

Package Sizing Overview (Based on two bedroom apartments)

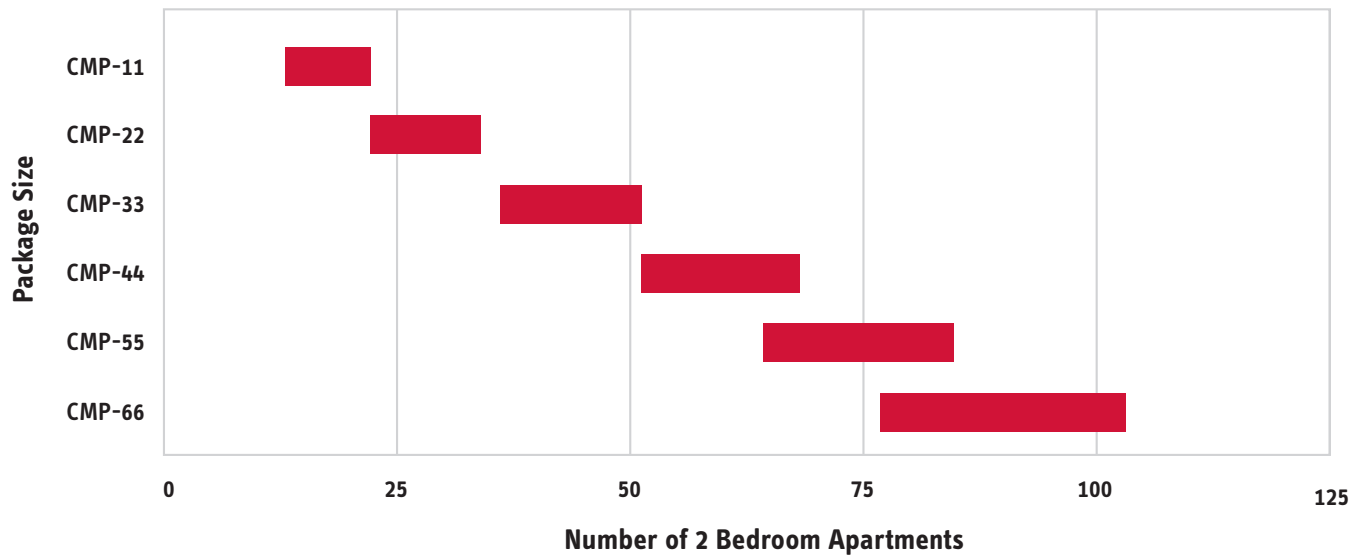

Ferrars & York, South Melbourne



CMP-11

Commercial Modular Premium 11

Specification wording

The hot water plant shall be a closed-loop heat pump system meeting the following requirements:

The system shall consist of one (1) WPL-A 07 air-to-water monobloc outdoor heat pump units, each coupled to one (1) 770 nominal domestic hot water (DHW) enamel steel tanks with high-efficiency insulation and removable jackets for narrow plant room installations with space restrains. The total heating output shall be 8kW at 5°C ambient air temperature with water temperatures up to 65°C directly from the tanks without reliance on electric boosting. The heat pumps shall be capable of achieving flow temperatures of up to 75°C and operate on R454C, a low Global Warming Potential (GWP) refrigerant.

The heat pumps shall operate in a true cascade, controlled by a centralised Heat Pump Manager to ensure uniform machine scheduling and optimal system performance. Reticulation recovery shall be supported through external boosters. The system shall feature an Internet Service Gateway connected to the Heat Pump Manager and a network router/switch, providing service visibility and building management system (BMS) integration via MODBUS protocol.

The system shall require a connected load of 55A at 230VAC, be WaterMark certified, and include tank insulation optimised for maximum efficiency. It shall be configured for indoor installation and comply with all relevant Australian Standards, offering long-term operational reliability and energy efficiency.

Package Name	CMP-11
HP Type	WPL A-07
QTY	1
Tanks	1
Heating Cylinder Volume (L)	770
Booster Volume (L)	315
Min. Spatial Requirement (m2)	5.78
Dry Weight (kg)	506.00
Wet Weight (kg)	1674.00
Connected load (A)	55.00
Peak Draw (kW)	9.30
Electrical Box Sub Main (V)	20A/PH 415V

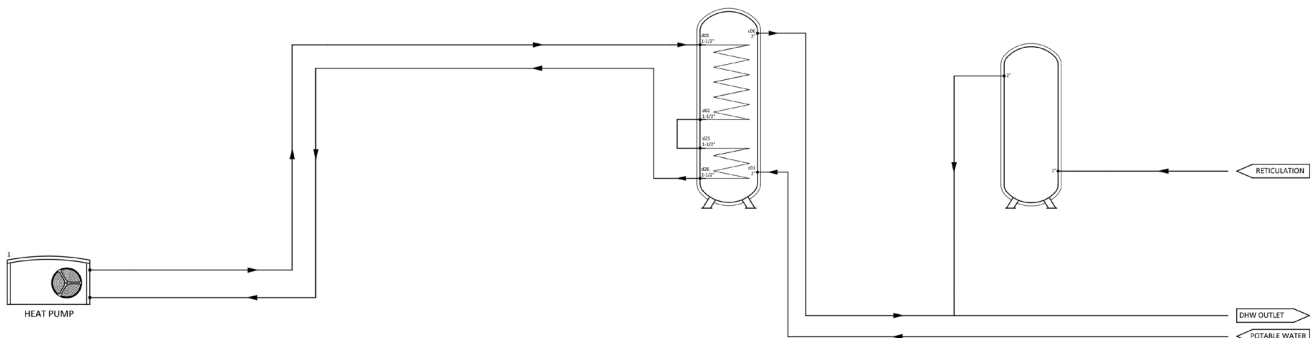

CMP-22

Commercial Modular Premium 22

Specification wording

The hot water plant shall be a closed-loop heat pump system meeting the following requirements:

The system shall consist of two (2) WPL-A 07 air-to-water monobloc outdoor heat pump units, each coupled to two (2) 770 nominal domestic hot water (DHW) enamel steel tanks with high-efficiency insulation and removable jackets for narrow plant room installations with space restraints. The total heating output shall be 16kW at 5°C ambient air temperature with water temperatures up to 65°C directly from the tanks without reliance on electric boosting. The heat pumps shall be capable of achieving flow temperatures of up to 75°C and operate on R454C, a low Global Warming Potential (GWP) refrigerant.

The heat pumps shall operate in a true cascade, controlled by a centralised Heat Pump Manager to ensure uniform machine scheduling and optimal system performance. Reticulation recovery shall be supported through external boosters. The system shall feature an Internet Service Gateway connected to the Heat Pump Manager and a network router/switch, providing service visibility and building management system (BMS) integration via MODBUS protocol.

The system shall require a connected load of 80A at 230VAC, be WaterMark certified, and include tank insulation optimised for maximum efficiency. It shall be configured for indoor installation and comply with all relevant Australian Standards, offering long-term operational reliability and energy efficiency.

Package Name	CMP-22
HP Type	WPL A-07
QTY	2
Tanks	2
Heating Cylinder Volume (L)	1540
Booster Volume (L)	315
Min. Spatial Requirement (m2)	9.02
Dry Weight (kg)	937.00
Wet Weight (kg)	2948.00
Connected load (A)	80.00
Peak Draw (kW)	13.80
Electrical Box Sub Main (V)	32A/PH 415V

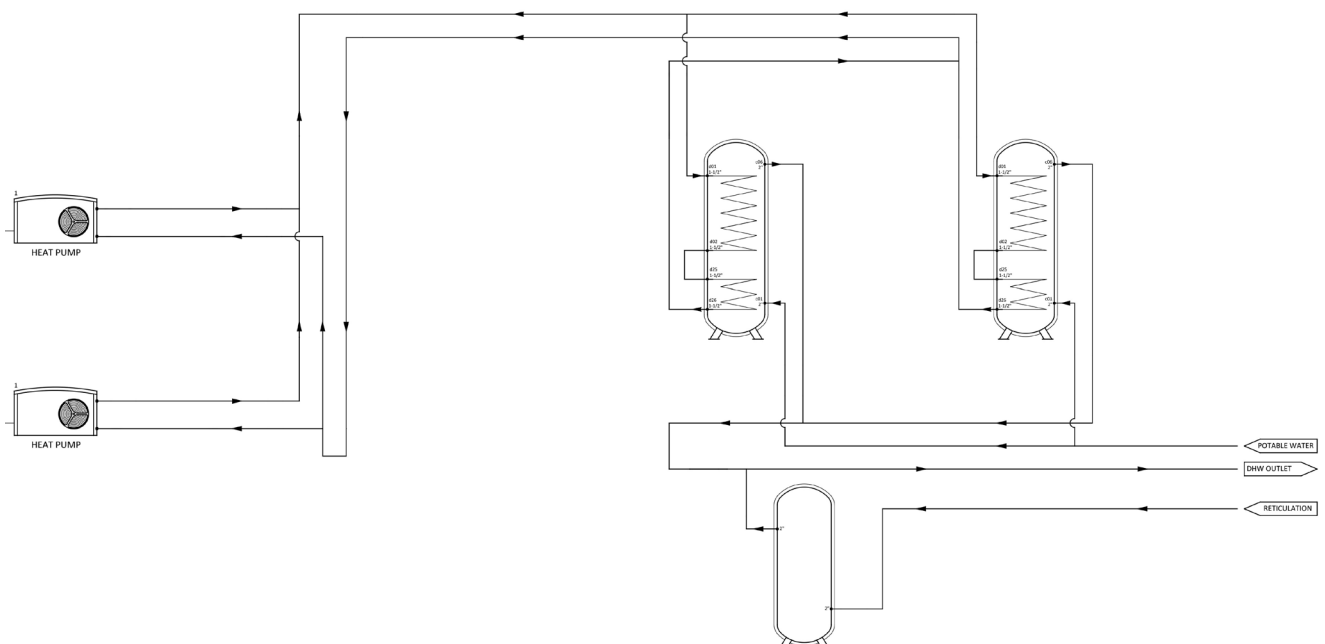

CMP-33

Commercial Modular Premium 33

Specification wording

The hot water plant shall be a closed-loop heat pump system meeting the following requirements:

The system shall consist of three (3) WPL-A 07 air-to-water monobloc outdoor heat pump units, each coupled to three (3) 770 nominal domestic hot water (DHW) enamel steel tanks with high-efficiency insulation and removable jackets for narrow plant room installations with space restraints. The total heating output shall be 24 kW at 5°C ambient air temperature with water temperatures up to 65°C directly from the tanks without reliance on electric boosting. The heat pumps shall be capable of achieving flow temperatures of up to 75°C and operate on R454C, a low Global Warming Potential (GWP) refrigerant.

The heat pumps shall operate in a true cascade, controlled by a centralised Heat Pump Manager to ensure uniform machine scheduling and optimal system performance. Reticulation recovery shall be supported through external boosters. The system shall feature an Internet Service Gateway connected to the Heat Pump Manager and a network router/switch, providing service visibility and building management system (BMS) integration via MODBUS protocol.

The system shall require a connected load of 105A at 230VAC, be WaterMark certified, and include tank insulation optimised for maximum efficiency. It shall be configured for indoor installation and comply with all relevant Australian Standards, offering long-term operational reliability and energy efficiency.

Package Name	CMP-33
HP Type	WPL A-07
QTY	3
Tanks	3
Heating Cylinder Volume (L)	2310
Booster Volume (L)	315
Min. Spatial Requirement (m2)	16.22
Dry Weight (kg)	1368.00
Wet Weight (kg)	4222.00
Connected load (A)	105.00
Peak Draw (kW)	18.30
Electrical Box Sub Main (V)	40A/PH 415V

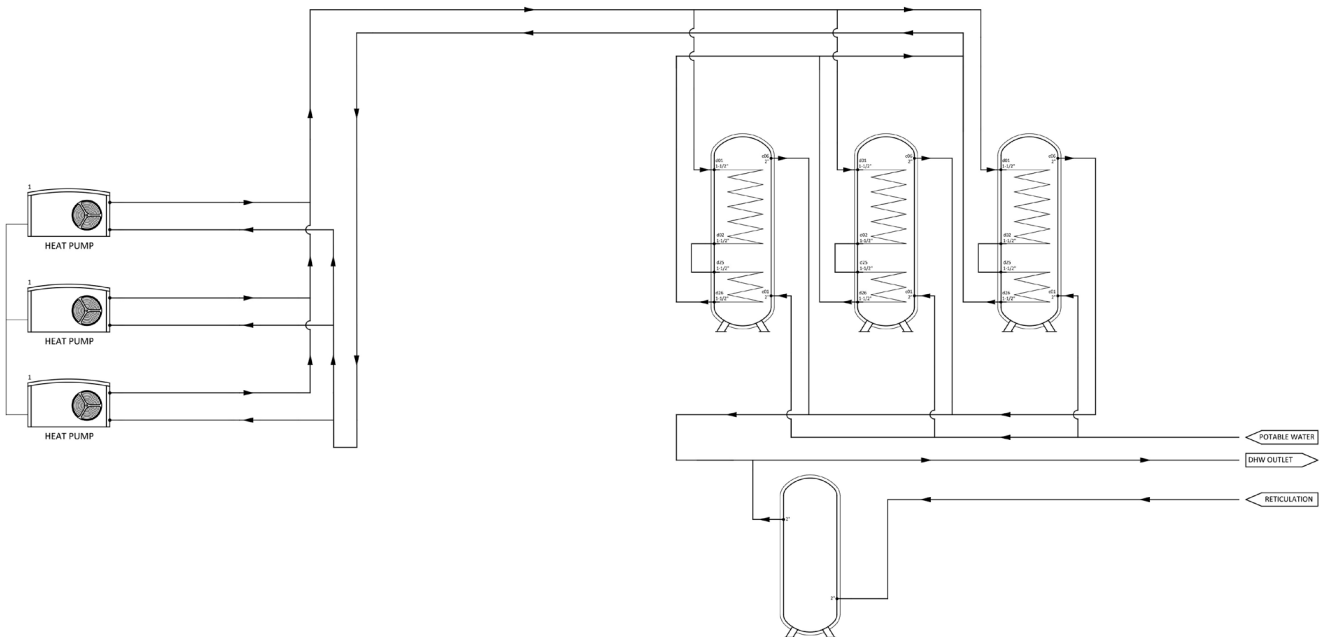

CMP-44

Commercial Modular Premium 44

Specification wording

The hot water plant shall be a closed-loop heat pump system meeting the following requirements:

The system shall consist of four (4) WPL-A 07 air-to-water monobloc outdoor heat pump units, each coupled to four (4) 770 nominal domestic hot water (DHW) enamel steel tanks with high-efficiency insulation and removable jackets for narrow plant room installations with space restraints. The total heating output shall be 32kW at 5°C ambient air temperature with water temperatures up to 65°C directly from the tanks without reliance on electric boosting. The heat pumps shall be capable of achieving flow temperatures of up to 75°C and operate on R454C, a low Global Warming Potential (GWP) refrigerant.

The heat pumps shall operate in a true cascade, controlled by a centralised Heat Pump Manager to ensure uniform machine scheduling and optimal system performance. Reticulation recovery shall be supported through external boosters. The system shall feature an Internet Service Gateway connected to the Heat Pump Manager and a network router/switch, providing service visibility and building management system (BMS) integration via MODBUS protocol.

The system shall require a connected load of 170A at 230VAC, be WaterMark certified, and include tank insulation optimised for maximum efficiency. It shall be configured for indoor installation and comply with all relevant Australian Standards, offering long-term operational reliability and energy efficiency.

Package Name	CMP-44
HP Type	WPL A-07
QTY	4
Tanks	4
Heating Cylinder Volume (L)	3080
Booster Volume (L)	315
Min. Spatial Requirement (m2)	14.92
Dry Weight (kg)	1799.00
Wet Weight (kg)	5496.00
Connected load (A)	170.00
Peak Draw (kW)	32.40
Electrical Box Sub Main (V)	63A/PH 415V

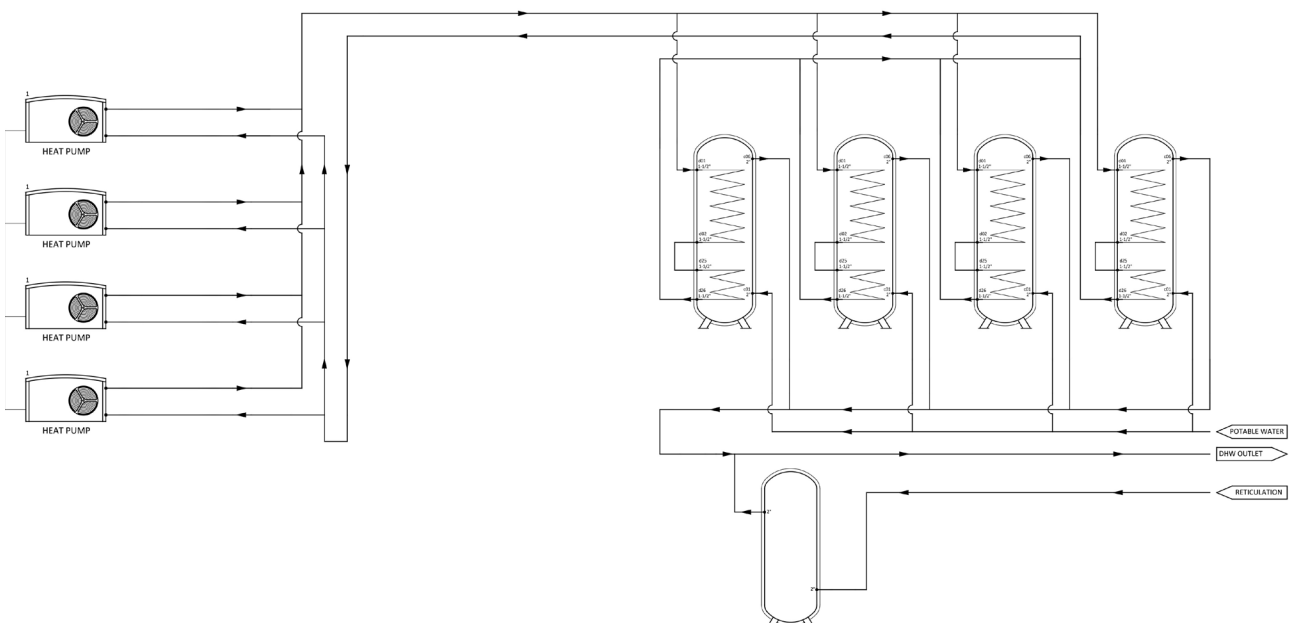

CMP-55

Commercial Modular Premium 55

Specification wording

The hot water plant shall be a closed-loop heat pump system meeting the following requirements:

The system shall consist of five (5) WPL-A 07 air-to-water monobloc outdoor heat pump units, each coupled to five (5) 770 nominal domestic hot water (DHW) enamel steel tanks with high-efficiency insulation and removable jackets for narrow plant room installations with space restraints. The total heating output shall be 40kW at 5°C ambient air temperature with water temperatures up to 65°C directly from the tanks without reliance on electric boosting. The heat pumps shall be capable of achieving flow temperatures of up to 75°C and operate on R454C, a low Global Warming Potential (GWP) refrigerant.

The heat pumps shall operate in a true cascade, controlled by a centralised Heat Pump Manager to ensure uniform machine scheduling and optimal system performance. Reticulation recovery shall be supported through external boosters. The system shall feature an Internet Service Gateway connected to the Heat Pump Manager and a network router/switch, providing service visibility and building management system (BMS) integration via MODBUS protocol.

The system shall require a connected load of 195A at 230VAC, be WaterMark certified, and include tank insulation optimised for maximum efficiency. It shall be configured for indoor installation and comply with all relevant Australian Standards, offering long-term operational reliability and energy efficiency.

Package Name	CMP-55
HP Type	WPL A-07
QTY	5
Tanks	5
Heating Cylinder Volume (L)	3850
Booster Volume (L)	315
Min. Spatial Requirement (m2)	19.51
Dry Weight (kg)	2230.00
Wet Weight (kg)	6770.00
Connected load (A)	195.00
Peak Draw (kW)	36.90
Electrical Box Sub Main (V)	80A/PH 415V

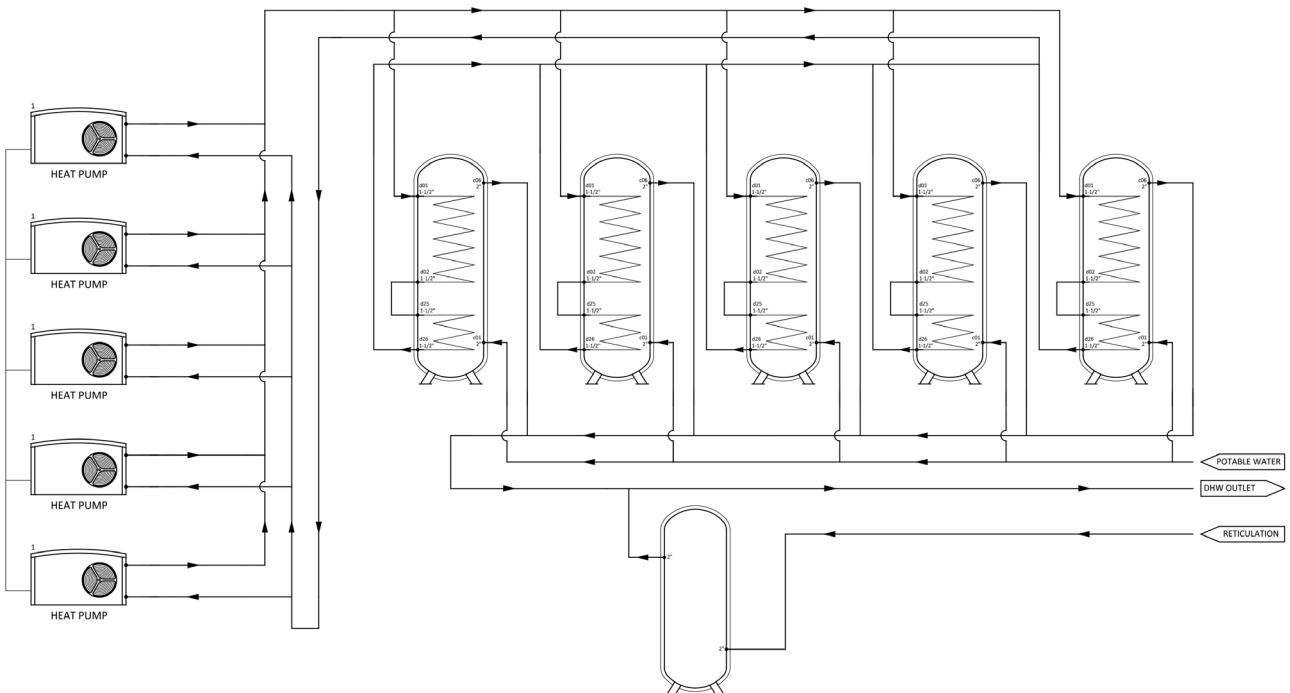

CMP-66

Commercial Modular Premium 66

Specification wording

The hot water plant shall be a closed-loop heat pump system meeting the following requirements:

The system shall consist of six (6) WPL-A 07 air-to-water monobloc outdoor heat pump units, each coupled to six (6) 770 nominal domestic hot water (DHW) enamel steel tanks with high-efficiency insulation and removable jackets for narrow plant room installations with space restraints. The total heating output shall be 48 kW at 5°C ambient air temperature with water temperatures up to 65°C directly from the tanks without reliance on electric boosting. The heat pumps shall be capable of achieving flow temperatures of up to 75°C and operate on R454C, a low Global Warming Potential (GWP) refrigerant.

The heat pumps shall operate in a true cascade, controlled by a centralised Heat Pump Manager to ensure uniform machine scheduling and optimal system performance. Reticulation recovery shall be supported through external boosters. The system shall feature an Internet Service Gateway connected to the Heat Pump Manager and a network router/switch, providing service visibility and building management system (BMS) integration via MODBUS protocol.

The system shall require a connected load of 220A at 230VAC, be WaterMark certified, and include tank insulation optimised for maximum efficiency. It shall be configured for indoor installation and comply with all relevant Australian Standards, offering long-term operational reliability and energy efficiency.

Package Name	CMP-66
HP Type	WPL A-07
QTY	6
Tanks	6
Heating Cylinder Volume (L)	4620
Booster Volume (L)	315
Min. Spatial Requirement (m2)	23.30
Dry Weight (kg)	2661.00
Wet Weight (kg)	8044.00
Connected load (A)	220.00
Peak Draw (kW)	41.40
Electrical Box Sub Main (V)	80A/PH 415V

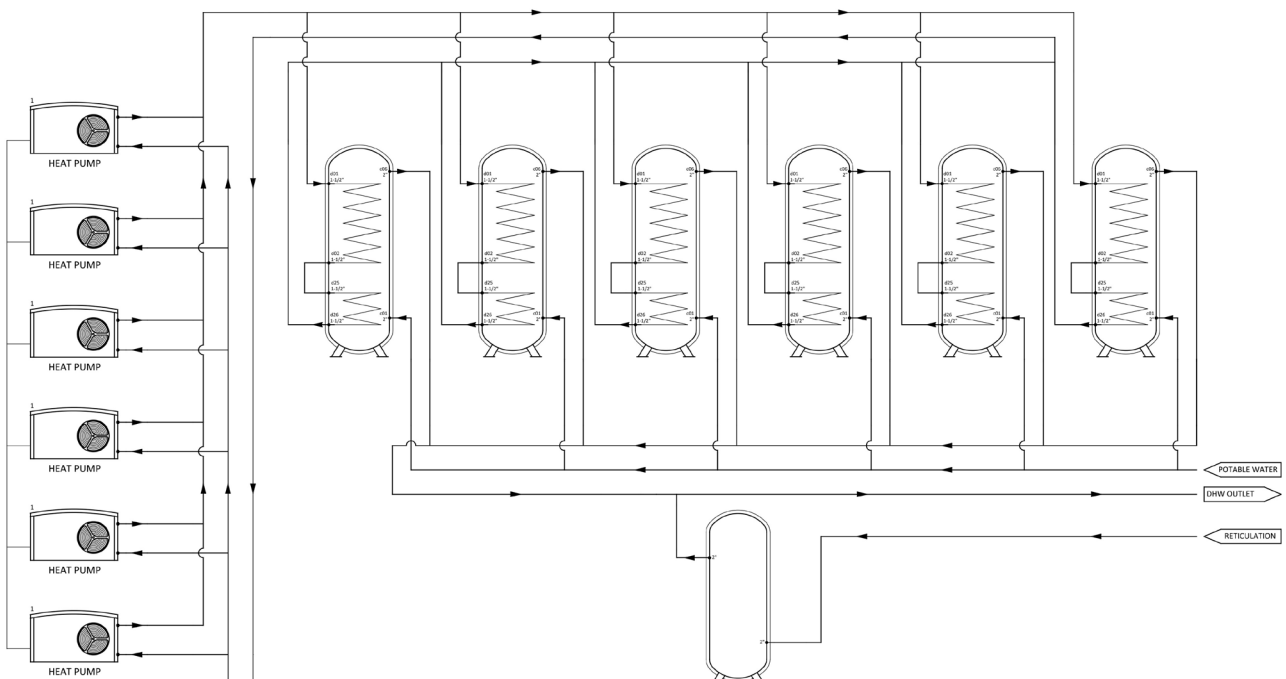

For new and interesting information on our products, visit www.stiebel-eltron.com.au or consult your local trade partner.

STIEBEL ELTRON

Legal notice | Although we have tried to make this brochure as accurate as possible, we are not liable for any inaccuracies in its content. Information concerning equipment levels and specifications are subject to modification. The equipment characteristics described in this brochure are non-binding regarding the specification of the final product. Due to our policy of ongoing improvement, some features may have subsequently been changed or even removed. Please consult your local trade partner for information about the very latest equipment features. The images in this brochure are for reference only. The illustrations also contain installation components, accessories and special equipment, which do not form part of the standard delivery. Reprinting of all or part of this brochure only with the publisher's express permission.